



STANDARD DETAILS

MAY 2018



Standard Details and Drawings Index

Drainage Detail Standard Drawings

FILE TYPE		STD No.	Technical Standards & Details Title
DWG	PDF	DR-1	Typical Storm Drain Compaction
DWG	PDF	DR-1	Manhole Adjustment Concrete Collar (New and Existing Manholes)
DWG	PDF	DR-3	Standard Brick Catch Basin (15" thru 54" Pipe) Adopted from NCDOT Standard NO. 840.01 Page 1 of 2
DWG	PDF	DR-3.1	Standard Brick Catch Basin (15" thru 54" Pipe) Adopted from NCDOT Standard NO. 840.01 Page 2 of 2
DWG	PDF	DR-4	Typical Brick Double Catch Basin 15" thru 36" Pipe
DWG	PDF	DR-5	Standard Brick Junction Box (With Manhole Access) 12" thru 66" Pipe Adopted from NCDOT Standard NO. 840.32
DWG	PDF	DR-6	Standard Traffic Bearing Junction Box - 42" and Under Pipes NCDOT Standard NO. 840.34 Page 1 of 2
DWG	PDF	DR-6.1	Standard Traffic Bearing Junction Box - 42" and Under Pipes NCDOT Standard NO. 840.34 Page 2 of 2
DWG	PDF	DR-7	Standard Brick Manhole 12" thru 36" Pipe Adopted from NCDOT Standard NO. 840.51
DWG	PDF	DR-8	Reinforced Brick Endwall Adopted from NCDOT Standard NO. 838.57
DWG	PDF	DR-9	Concrete Base Pad for Drainage Structures Adopted from NCDOT Standard NO. 840.00
DWG	PDF	DR-10	Concrete Pipe Collar for Repairing Storm Drains Adopted from NCDOT Standard NO. 840.00
DWG	PDF	DR-11	Drop Inlet with Grate 12" to 30" Pipe NCDOT Standard NO. 840.15
DWG	PDF	DR-12	Fence Plan at Endwall
DWG	PDF	DR-13	Standard Manhole Ring and Cover Adopted from NCDOT Standard NO. 840.54
DWG	PDF	DR-14	4-Foot Diameter Precast Reinforced Concrete Manhole Sections
DWG	PDF	DR-14.1	5-Foot Diameter Precast Reinforced Concrete Manhole Sections
DWG	PDF	DR-15	Standard Masonry Endwall for Single & Double Pipe Culverts (15" - 48" Pipe) 90° Skew; NCDOT Standard NO. 838.11 Page 1 of 2
DWG	PDF	DR-15.1	Standard Masonry Endwall for Single & Double Pipe Culverts (15" - 48" Pipe) 90° Skew; NCDOT Standard NO. 838.11 Page 2 of 2
DWG	PDF	DR-16	Open Throat Junction Box

DWG	PDF	DR-17	Traffic Bearing Drop Inlet for Cast Iron Double Frame and Grates Adopted from NCDOT Standard NO. 840.35 Page 1 of 2
DWG	PDF	DR-17.1	Traffic Bearing Drop Inlet for Cast Iron Double Frame and Grates NCDOT Standard NO. 840.35 Page 2 of 2
DWG	PDF	DR-18	Precast Concrete Headwall System 12" thru 72" Pipe
DWG	PDF	DR-19	Reinforced Concrete Sewer Storm Drain and Culvert 15" thru 36" Pipe
DWG	PDF	DR-19.1	Reinforced Concrete Sewer Storm Drain and Culvert 42" thru 72" Pipe
DWG	PDF	DR-19.2	Minimum Slope & Cover for Storm Drain and Culvert Pipe
DWG	PDF	DR-20	Precast Concrete Solid Box Page 1 of 2
DWG	PDF	DR-20.1	Precast Concrete Solid Box Page 1 of 2
DWG	PDF	DR-21	Concrete Paved Swales
DWG	PDF	DR-23	Reinforced Precast Concrete Flared End Sections
DWG	PDF	DR-24	Pipe Outlet
DWG	PDF	DR-26	Standard Frame, Grates, and Hood for Use on Standard Catch Basin Adopted from NCDOT Standard NO. 840.03 Page 1 of 2
DWG	PDF	DR-26.1	Standard Frame, Grates, and Hood for Use on Standard Catch Basin Adopted from NCDOT Standard NO. 840.03 Page 2 of 2

Erosion Control Detail Standard Drawings

FILE TYPE		STD No.	Technical Standards & Details Title
DWG	PDF	EC-1	Typical Block and Gravel Drop Inlet Protection
DWG	PDF	EC-1.1	Typical Block Drop Inlet Protection
DWG	PDF	EC-1.2	Typical Excavated Drop Inlet Protection
DWG	PDF	EC-1.3	Typical Hardware Cloth and Gravel Drop Inlet Protection
DWG	PDF	EC-1.4	Temporary Rock Doughnut Inlet Protection
DWG	PDF	EC-2	Gravel Construction Entrance / Exit
DWG	PDF	EC-3	Temporary Sediment Trap
DWG	PDF	EC-4	Baffle Installation
DWG	PDF	EC-5	High Hazard Temporary Silt Fence
DWG	PDF	EC-6	Temporary Rock Check Dam
DWG	PDF	EC-7	Permanent Seeding Schedule
DWG	PDF	EC-8	Temporary Seeding Schedule (Seasonal)

Street Design Detail Standard Drawings

FILE TYPE		STD No.	Technical Standards & Details Title
DWG	PDF	SD-1	24" and 30" Curb Details
DWG	PDF	SD-2	Wheelchair Ramp with Sidewalk Off Back of Curb
DWG	PDF	SD-2.1	Wheelchair Ramp with Sidewalk Off Back of Curb
DWG	PDF	SD-2.2	Wheelchair Ramp with Pedestrian Crosswalks and Stop Lines
DWG	PDF	SD-2.3	Wheelchair Ramp Notes Sheet 4 of 4
DWG	PDF	SD-2.4	Detail of Parallel Curb Wheelchair Ramp
DWG	PDF	SD-2.5	Truncated Dome Details
DWG	PDF	SD-2.6	Detail of Mid-Block Parallel Curb Wheelchair Ramp
DWG	PDF	SD-2.7	Directional Curb Ramp
DWG	PDF	SD-2.8	Parallel Curb Single Wing Wheelchair Ramp
DWG	PDF	SD-3	Contraction and Expansion Joint
DWG	PDF	SD-4	Standard Catch Basin Transition for 24" Roll Curb and Gutter Adopted from NCDOT Standard NO. 852.05
DWG	PDF	SD-5	Standard Catch Basin Transition for 24" Vertical Curb and Gutter Adopted From NCDOT Standard NO. 852.05
DWG	PDF	SD-6	Driveway Connections to Overlaid or Raised Curbing (Uphill Driveway) Page 1 of 2
DWG	PDF	SD-6.1	Driveway Connections to Overlaid or Raised Curbing (Downhill Driveway) Page 2 of 2
DWG	PDF	SD-7	Concrete Valley Gutter Detail
DWG	PDF	SD-8	Standard Minimums for Residential and Commercial Cul-De-Sacs
DWG	PDF	SD-9	Typical Residential Driveway Apron
DWG	PDF	SD-9.1	Typical Commercial Driveway Apron
DWG	PDF	SD-10	Pipe Handrail
DWG	PDF	SD-11	Typical Temporary Sawcut and Pavement Patch Page 1 of 3
DWG	PDF	SD-11.1	Typical Permanent Sawcut and Pavement Patch Page 2 of 3
DWG	PDF	SD-11.2	Notes for Typical Permanent and Temporary Sawcut and Pavement Patch Page 3 of 3
DWG	PDF	SD-12	Typical Sidewalk Section
DWG	PDF	SD-14	Typical Minimum Standard 2 Lane Street Section for Residential Use
DWG	PDF	SD-15	Typical Street Section For 60' Pavement (Vertical Curb)
DWG	PDF	SD-16	Typical Minimum Section for 3 Lane Streets
DWG	PDF	SD-16.1	Typical Minimum Standard Street Sections for 2 Lane and 4 Lane Divided Streets with Median
DWG	PDF	SD-16.2	Typical Cross Sections for All City Pavement

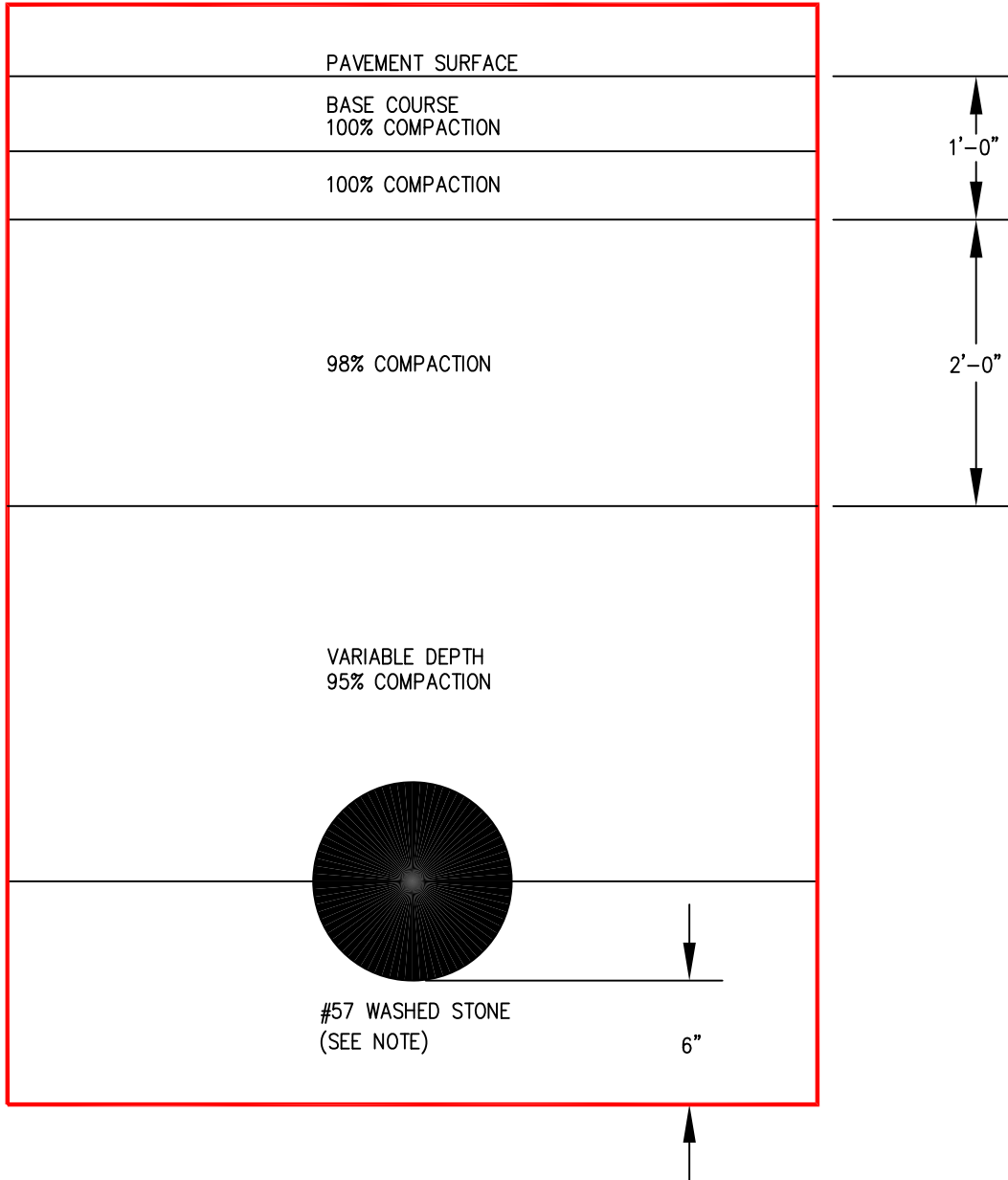

NOTES:

1. STONE BEDDING FOR PIPE IS REQUIRED UNLESS OTHERWISE APPROVED BY CITY ENGINEER OR THEIR DESIGNEE.

	ENGINEERING DIVISION
	433 HAY ST. 28301 (910) 433-1656 http://www.fayettevillenc.gov

TYPICAL STORM DRAIN
COMPACTION

Rev. Date: 16JAN18 Not to Scale	DR-1
------------------------------------	------

NOTES:

1. EXCAVATE ALL MATERIAL FROM AROUND CASTING TO A WIDTH OF 12" AND TO A DEPTH OF AT LEAST 2" BELOW EXISTING BRICKWORK OR EXISTING STRUCTURE. REMOVE AND DISPOSE OF ALL LOOSE MATERIAL.

2. DETERMINING THE CASTING ADJUSTMENT: THE HEIGHT OF CASTING ADJUSTMENT SHALL BE DETERMINED BY THE USE OF A STRING LINE. THE STRING LINE IS TO BE PULLED ACROSS CASTING AND FOR AT LEAST 10FT ON EACH SIDE OF CASTING PARALLEL TO CURB. HOLD STRING AT A HEIGHT OF ADJUSTMENT. EXAMPLE: 1" ABOVE EXISTING PAVEMENT FOR RESURFACING AND/OR 2" ABOVE SAND/CLAY OR STONE BASE. THEN STRING IS PULLED PERPENDICULAR ACROSS CASTING FROM EDGE OF PAVEMENT AT CURB TO CENTERLINE OF STREET. THE STRING SHALL BE SET AT SAME ADJUSTMENT HEIGHT. EVERY EFFORT SHALL BE TAKEN TO ENSURE THAT THE SURFACE COURSE AND CASTING SHALL PROVIDE AS SMOOTH A RIDE AS POSSIBLE.

3. ADJUSTMENT OF CASTING BY RAISING: ALL BRICKS ARE TO BE PLACED IN "SPOKE" PATTERN AND LAID IN A BED OF CLEAN FRESH MORTAR. THEN CONTRACTOR IS TO ENSURE ALL BRICKS ARE SET FIRM TO ELIMINATE MOVEMENT OF CASTING.

4. ADJUSTMENT OF CASTING BY LOWERING: ALL BRICKS AND CONCRETE ARE TO BE CUT AWAY, LEAVING A SMOOTH SURFACE. A CAP OF CLEAN FRESH MORTAR SHALL BE APPLIED TO SURFACE AS A SETTING BED FOR CASTING.

5. THE CASTING IS THEN PLACED BACK ON BRICKS AND CARE SHALL BE TAKEN TO ENSURE THAT IT IS SET ON BED OF CLEAN FRESH MORTAR TO ELIMINATE MOVEMENT. MORTAR SHALL MEET REQUIREMENTS OF NCDOT STANDARD SPECIFICATIONS SECTION 1040-9 FOR MORTAR AND SECTION 1014-1 FOR MORTAR SAND.

6. THE EXCAVATED AREA SHALL THEN BE BACKFILLED WITH 3000 PSI PORTLAND CEMENT CONCRETE LEVEL TO EXISTING SURFACE. THE TOP OF CONCRETE SHALL THEN BE STRUCK SMOOTH WITH EXISTING SURFACE. CASTING TO BE CLEANED OF ANY CONCRETE SPILLAGE. ASPHALT SHALL NOT BE USED TO BACKFILL AROUND CASTING.

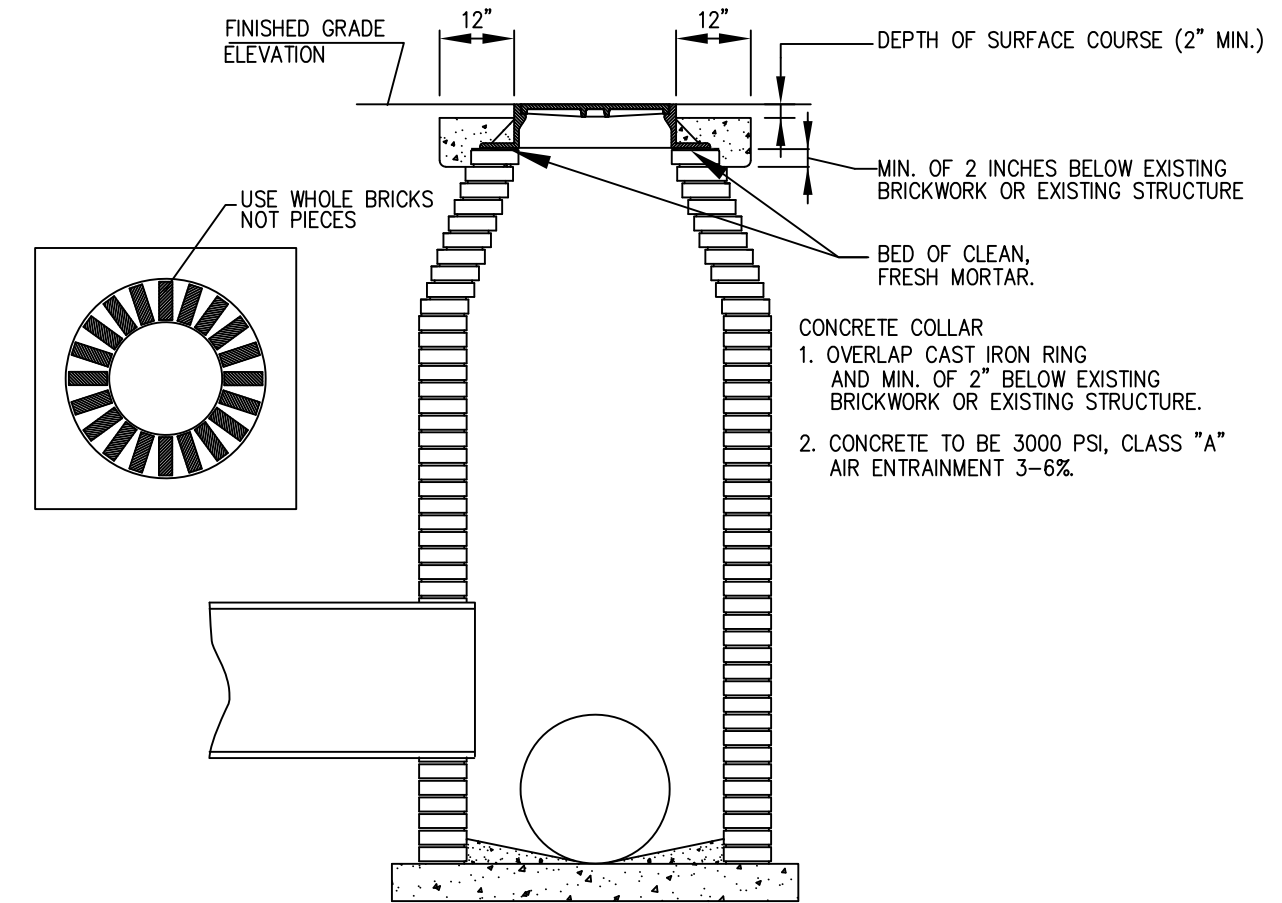

7. ALL ADJUSTMENTS SHALL THEN BE PROTECTED FOR AT LEAST 72 HOURS BEFORE THE PLACEMENT OF ANY SURFACING MATERIAL. A FINISH SURFACE TOLERANCE SHALL NOT VARY MORE THAN 1/4 INCH IN ANY DIRECTION.



ENGINEERING DIVISION
433 HAY ST. 28301
(910) 433-1656
<http://www.fayettevillenc.gov>

**STANDARD DETAIL
MANHOLE ADJUSTMENT
CONCRETE COLLAR
(NEW AND EXISTING MANHOLES)**

Rev. Date: 16JAN18
Not to Scale

DR-2

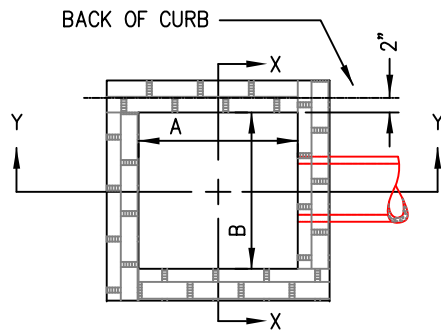

PLAN

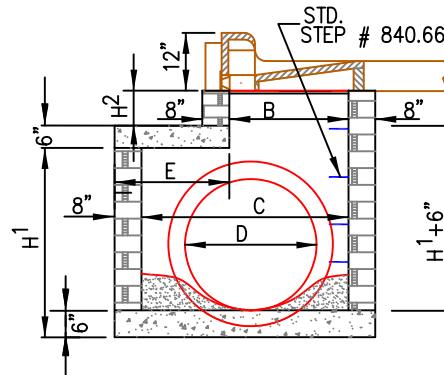

**END ELEVATION
SECTION J-J**

WHERE 30" TO 36" PIPE IS USED

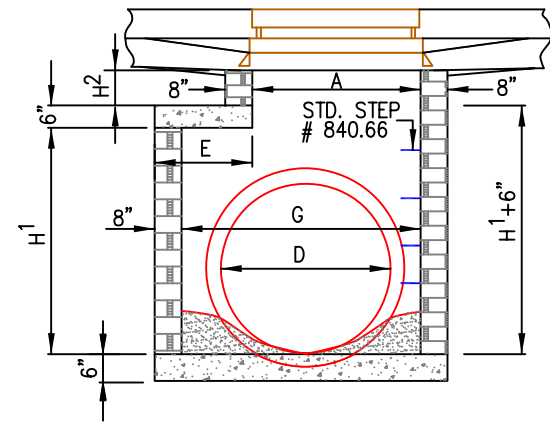

**END ELEVATION
SECTION Y-Y**

WHERE 42" TO 54" PIPE IS USED

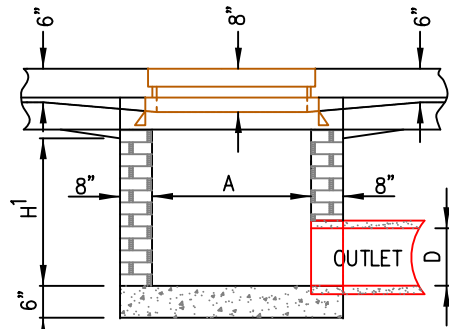

SECTION Y-Y

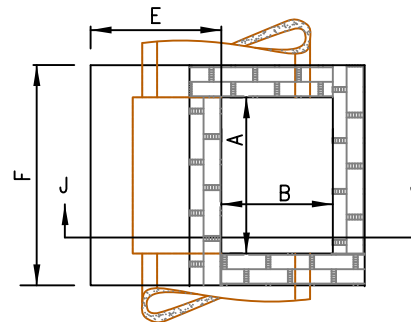

PLAN

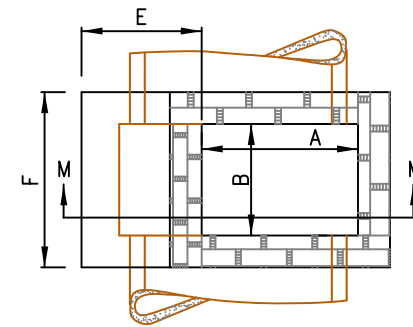

PLAN

GENERAL NOTES:

1. MORTAR JOINTS 1/2" 1/8" THICK.
2. 3000 P.S.I. CONCRETE TO BE USED.
3. THE POURING OF FLOOR SLAB TO BE ACCOMPLISHED BY FORMING.
4. ALL CATCH BASINS OVER 3'-6" IN DEPTH SHALL BE PROVIDED WITH STEPS 1' -2" ON CENTERS.
5. USE TYPE "E", "F", & "G" GRATE UNLESS OTHERWISE INDICATED.
6. JUMBO BRICK WILL BE PERMITTED. CONCRETE BRICK OR 4" SOLID CONCRETE BLOCKS MAY BE USED IN LIEU OF CLAY BRICKS.
7. FOR 8' -0" IN HEIGHT OR LESS USE 8" WALL. OVER 8' -0" IN HEIGHT USE 12" WALL TO 6' -0" FROM TOP OF WALL, 8" WALL FOR THE UPPER 6' -0".
8. INVERTS SHALL BE SHAPED TO FORM A SMOOTH, REGULAR SURFACE, SLOPED TO PREVENT SEDIMENTATION.
9. FOR VARIABLE DIMENSIONS, SEE STANDARD DETAIL DR-3.1.

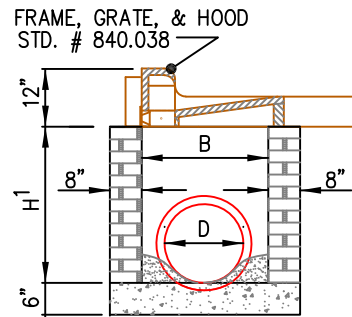

SECTION X-X

Fayetteville
North Carolina

ENGINEERING DIVISION
433 HAY ST. 28301
(910) 433-1656
<http://www.fayettevillenc.gov>

**STANDARD BRICK CATCH BASIN
(15" THRU 54" PIPE)
ADOPTED FROM NCDOT STANDARD NO. 840.01
PAGE 1 OF 2**

Rev. Date: 16JAN18
Not to Scale

DR-3

**DIMENSIONS AND QUANTITIES FOR BRICK CATCH BASIN
(LOCATION OF SOME VARIABLES SHOWN IN STANDARD DETAIL SD-3)**

DIMENSIONS OF BOX AND PIPE							COVER DIMENSION		REINFORCING				* CUBIC YARDS OF CONCRETE IN BOX			BRICK MASON		DEDUCTIONS FOR ONE PIPE				
PIPE	SPAN	WIDTH	WIDTH	SPAN	HEIGHT	HEIGHT	E	F	BARS-U		BARS-V		BARS-W		TOTAL	TOP SLAB	FLOOR	TOTAL	CU. YDS. H1	CU. YDS. PER FT.HT.	C.M.	R.C.
D	A	B	C	G	MIN. H 1	H 2			NO	LENGTH	NO	LENGTH	NO	LENGTH	LBS.					ABOVE MIN. H 1		
15"	3'-0"	2'-2"	-	-	3'-0"	-	-	-	-	-	-	-	-	-	-	-	0.281	0.281	0.963	0.321	0.0308	0.047
18"					3'-3"												0.281	0.281	1.043	0.321	0.0442	0.065
24"					3'-9"												0.281	0.281	1.204	0.321	0.0784	0.121
30"			3'-4"		4'-3"		1'-2"	4'-4"	4	1'-6"	3	4'-1"	3	4'-1"	45	0.147	0.374	0.521	1.606	0.321	0.1224	0.184
36"			3'-10"		4'-9"		1'-8"	4'-4"	4	2'-0"	4	4'-1"	3	4'-1"	49	0.187	0.415	0.602	1.914	0.321	0.1760	0.261
42"				4'-5"	5'-3"		1'-5"	3'-6"	4	1'-9"	3	3'-3"	3	3'-3"	38	0.135	0.373	0.508	2.152	H2	0.2400	0.371
48"				5'-0"	5'-9"		2'-0"	3'-6"	4	2'-6"	4	3'-3"	3	3'-3"	41	0.173	0.410	0.583	2.415		0.3131	0.477
54"	3'-0"	2'-2"		5'-7"	6'-3"		2'-7"	3'-6"	4	3'-0"	6	3'-3"	3	3'-3"	47	0.211	0.448	0.659	2.806		0.3958	0.595

* CONCRETE TO BE PAID FOR AS BRICK MASONRY

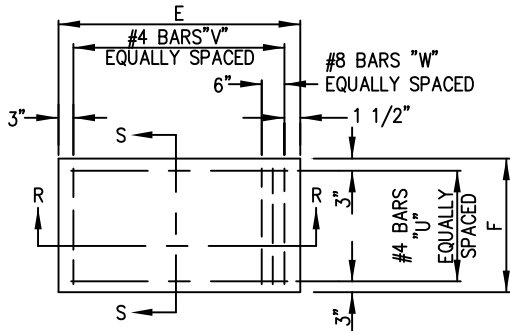

PLAN OF TOP SLAB

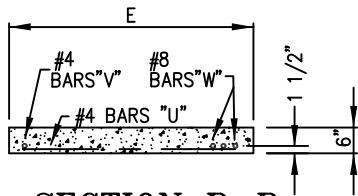

SECTION R-R

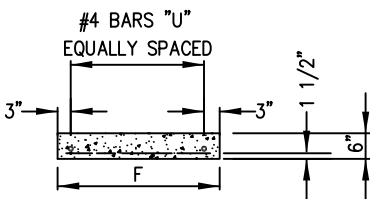

SECTION S-S

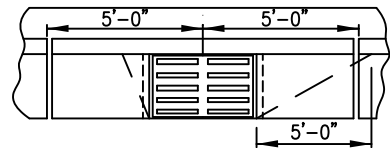

PLAN CURB AND GUTTER WITH CATCH BASIN ON STEEP GRADES

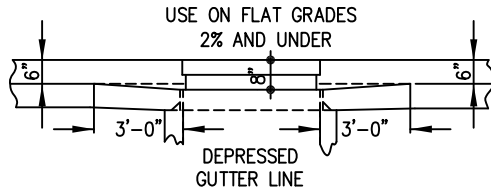

ELEVATION NORMAL CURB AND GUTTER ON LIGHT GRADES

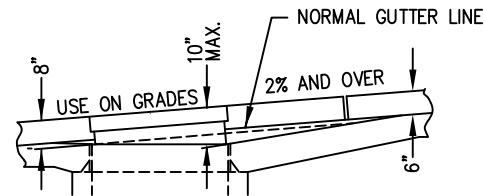

ELEVATION NORMAL CURB AND GUTTER ON STEEP GRADES

NOTE:
SEE GENERAL NOTES ON STANDARD DETAIL SD-3

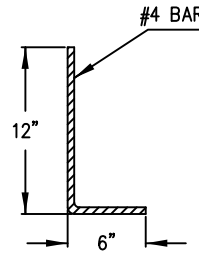

DOWEL

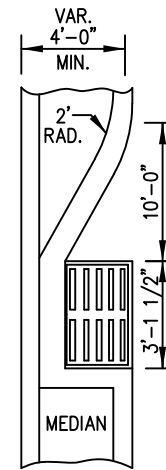

LAYOUT USE ON GRADE

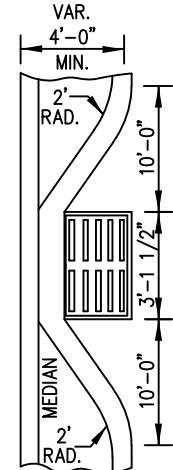

LAYOUT USE ON SAG VERTICAL

**CATCH BASIN INSTALLATION
IN MEDIAN WHERE
8"X6" CURB IS USED
(NOT TO BE USED ON FEDERAL-AID PROJECT)**



ENGINEERING DIVISION
433 HAY ST. 28301
(910) 433-1656
<http://www.fayettevillenc.gov>

**STANDARD BRICK CATCH BASIN
(15" THRU 54" PIPE)
ADOPTED FROM NCDOT STANDARD NO. 840.01
PAGE 2 OF 2**

Rev. Date: 16JAN18
Not to Scale

DR-3.1

GENERAL NOTES:

1. INSTALLATION REQUIRES A MINIMUM OF ONE 4'-0" LONG SECTION OF REINFORCED CONCRETE PIPE BETWEEN CATCH BASINS.
2. SEE NCDOT STANDARD 840.01 FOR DETAILS BASED ON PIPE SIZE PER CROSS SECTION.
3. CONSTRUCT TWO SINGLE BASINS PER NCDOT STANDARD WITH DOUBLE INTERIOR WALL.
4. ALL CONCRETE TO BE 3000 P.S.I COMPRESSIVE STRENGTH.
5. BASE SLAB SHALL BE MONOLITHIC.
6. SEE CITY OF FAYETTEVILLE STANDARDS SD-4 AND SD-5 FOR PLACEMENT OF CATCH BASIN.
7. PIPE SECTION D2 CONNECTING CATCH BASINS SHALL HAVE A MINIMUM DIAMETER SAME AS OF OUTLET PIPE D3.
8. ALL REINFORCING STEEL SHOWN ON NCDOT STANDARDS IS TO BE PROVIDED AS CONTINUOUS MEMBERS. (NO LAPS, USED AS A SINGLE CONTINUOUS BAR IN THE SLAB)

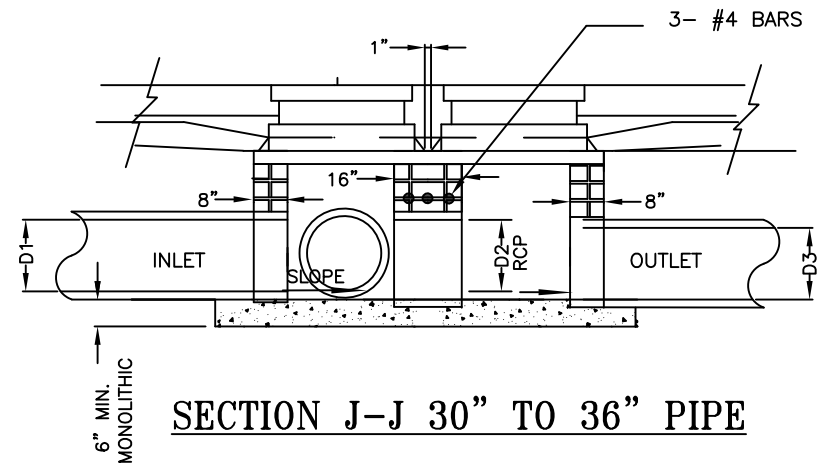
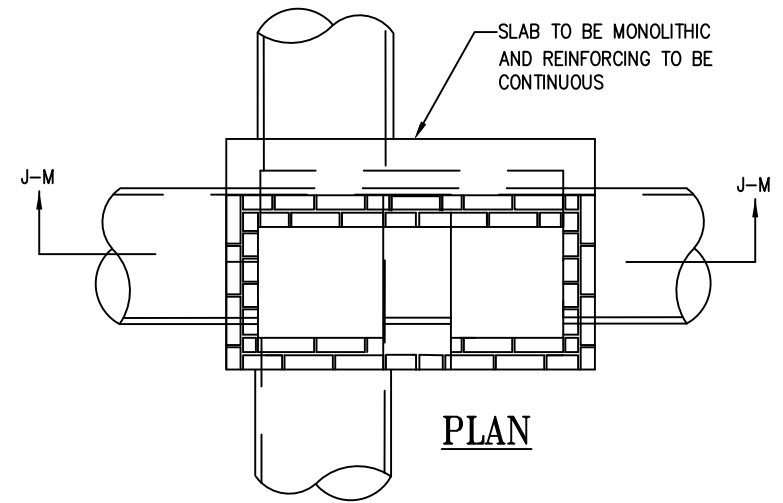
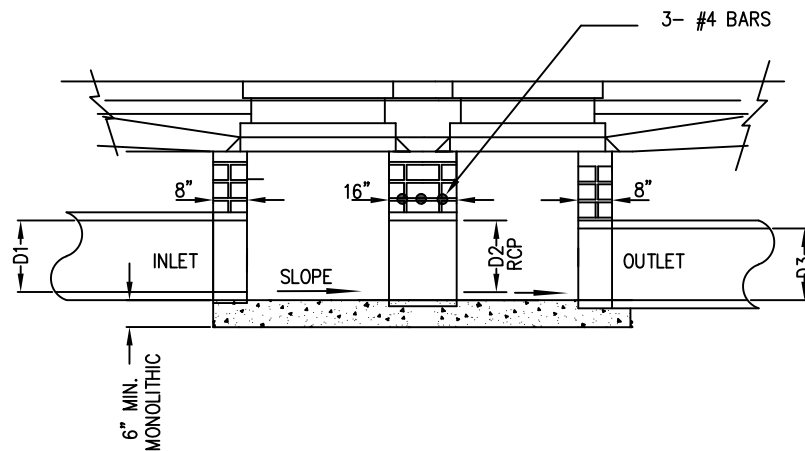
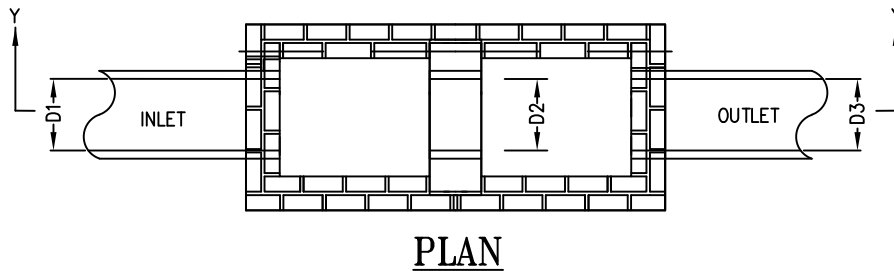

Fayetteville
North Carolina

ENGINEERING DIVISION
433 HAY ST. 28301
(910) 433-1656
<http://www.fayettevillenc.gov>

TYPICAL BRICK DOUBLE CATCH
BASIN 15" THRU 36" PIPE

Rev. Date: 16JAN18
Not to Scale

DR-4

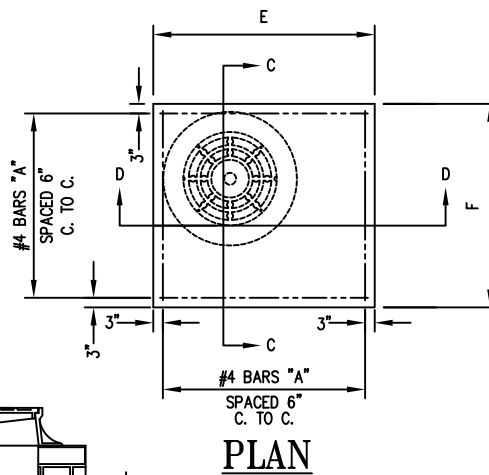
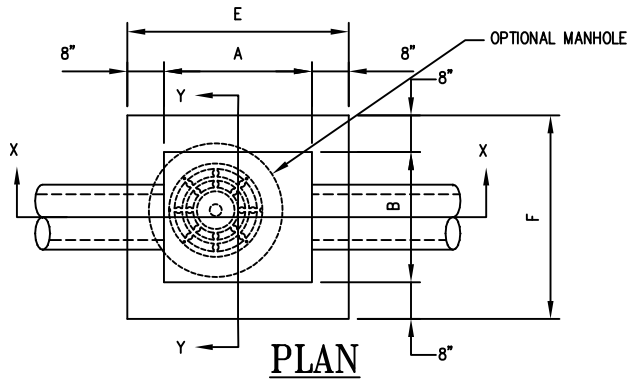

SEE NCDOT STD 840.54 FOR MANHOLE COVER & FRAME

BRICK MAY BE USED TO ADJUST FRAME & COVER TO SURFACE ELEVATION MAX. 1'

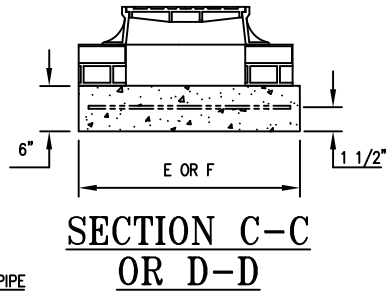
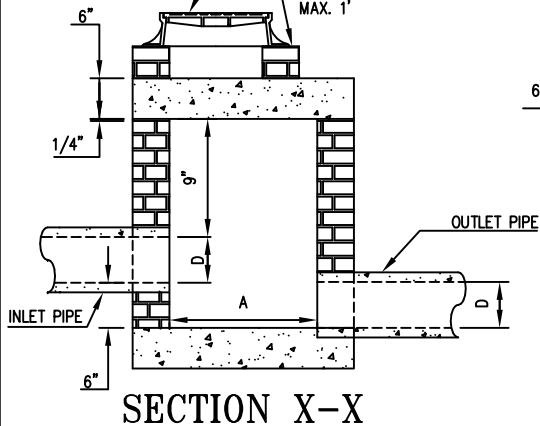

SEE NCDOT STD 840.54 FOR MANHOLE COVER & FRAME

BRICK MAY BE USED TO ADJUST FRAME & COVER TO SURFACE ELEVATION MAX. 1'

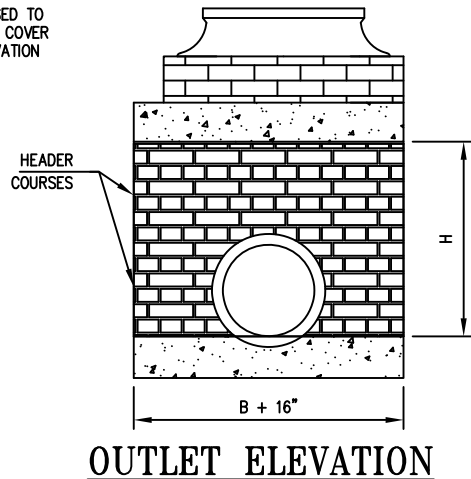
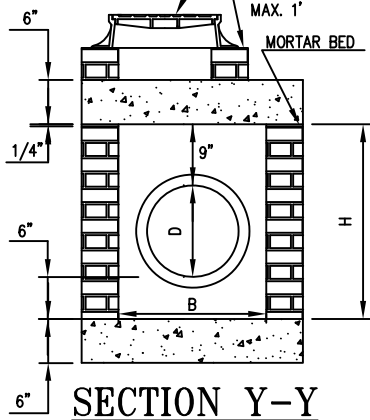

GENERAL NOTES:

ALL EXPOSED CORNERS TO BE CHAMFERED 1".
CLASS "B" CONCRETE TO BE USED.
MOTAR JOINTS 1/2" ± 1/8" THICK.
ALL EXPOSED JOINTS SHALL BE CONCAVE TOOLED.

FORMS ARE TO BE USED FOR THE CONSTRUCTION OF THE SLAB.

JUMBO BRICK WILL BE PERMITTED. CONCRETE BRICK OR 4" SOLID CONCRETE BLOCKS SHALL BE USED.

FOR 8'-0" IN HEIGHT OR LESS, USE 8" WALL. OVER 8'-0" IN HEIGHT, USE 12" WALL TO 6'-0" FROM TOP OF WALL, AND 8" WALL FOR THE REMAINING 6'-0". DIMENSIONS AND QUANTITIES TO BE ADJUSTED ACCORDINGLY.

IF REINFORCED CONCRETE PIPE IS SET IN BASE SLAB OF BOX, ADD TO BASE AS SHOWN ON STANDARD NO. 840.00.

ALL JUNCTION BOXES OVER 3'-6" IN DEPTH SHALL BE PROVIDED WITH STEPS 12"-16" ON CENTERS. STEPS SHALL BE IN WITH NCDOT STD. NO. 840.66.

ADJUST THE STEEL, CONCRETE AND BRICK MASONRY QUANTITIES TO INCLUDE THE ADDITION OF THE MANHOLE (I.E. DIAGONAL BARS SHORTENED AROUND OPENING IN TOP SLAB, ADDITIONAL VARIABLE HEIGHT BRICK MASONRY, OPENING IN TOP SLAB.)

DIMENSIONS AND QUANTITIES FOR BRICK JUNCTION BOXES												
DIM'S OF BOX & PIPE				REINFORCEMENT		COVER		CUBIC YARDS			DEDUCTIONS FOR ONE	
PIPE	SPAN	WIDTH	HEIGHT	NO.	LENGTH	DIMENSIONS		CONC.	BRICK	MASONRY	PIPE CU. YDS.	
D	A	B	H			E	F	BASE & COVER CU. YD.	MIN. HEIGHT CU. YD.	WALL PER FT. HT. CU. YD.	C.S.	R.C.
15"	2'-0"	2'-0"	2'-6"	12	3'-1"	3'-4"	3'-4"	0.412	0.657	0.263	0.031	0.047
18"	2'-4"	2'-4"	2'-9"	14	3'-5"	3'-8"	3'-8"	0.498	0.814	0.296	0.044	0.065
24"	3'-0"	3'-0"	3'-3"	16	4'-1"	4'-4"	4'-4"	0.695	1.176	0.362	0.078	0.113
30"	3'-4"	3'-4"	3'-9"	16	4'-5"	4'-8"	4'-8"	0.807	1.481	0.395	0.122	0.170
36"	4'-0"	4'-0"	4'-3"	20	5'-1"	5'-4"	5'-4"	1.053	1.959	0.461	0.176	0.238
42"	4'-8"	4'-8"	4'-9"	22	5'-9"	6'-0"	6'-0"	1.333	2.503	0.527	0.240	0.323
48"	5'-4"	5'-4"	5'-3"	26	6'-5"	6'-8"	6'-8"	1.646	2.940	0.560	0.313	0.422
54"	5'-10"	5'-10"	5'-9"	28	6'-11"	7'-2"	7'-2"	1.902	3.502	0.609	0.396	0.535
60"	6'-6"	6'-6"	6'-3"	30	7'-7"	7'-10"	7'-10"	2.272	4.113	0.658	0.489	0.660
66"	7'-1"	7'-1"	6'-9"	32	8'-2"	8'-5"	8'-5"	2.624	4.778	0.708	0.591	0.798



ENGINEERING DIVISION
433 HAY ST. 28301
(910) 433-1656
<http://www.fayettevillenc.gov>

**STANDARD BRICK JUNCTION BOX
(WITH MANHOLE ACCESS) 12" THRU 66" PIPE
ADOPTED FROM NCDOT STANDARD
NO. 840.32**

Rev. Date: 16JAN18
Not to Scale

DR-5

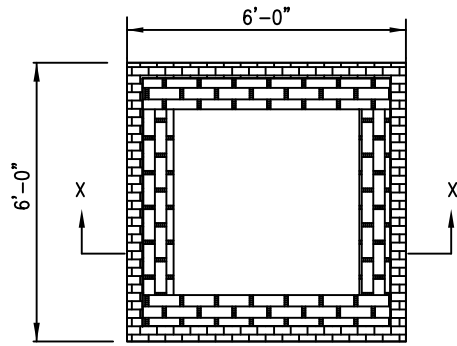

PLAN
(WITHOUT TOP)

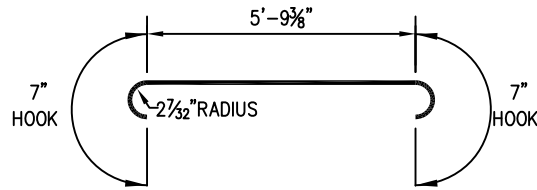

"Y" BARS
BAR DIMENSIONS ARE OUT TO OUT

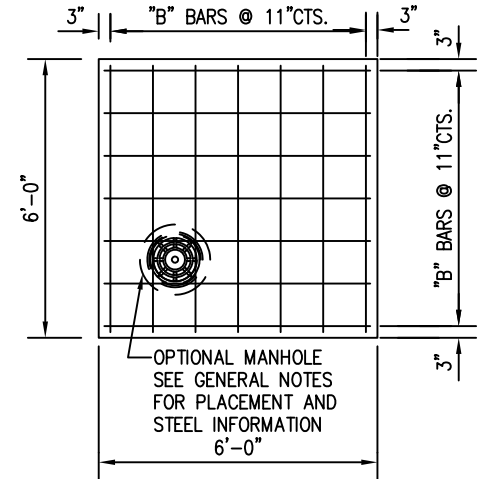

PLAN OF TOP SLAB

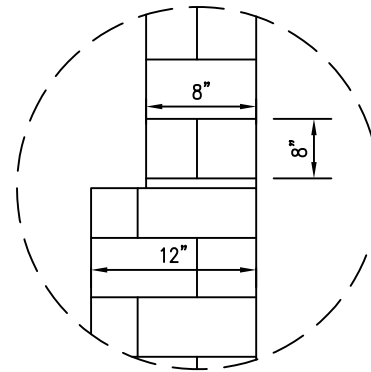

INSET "A"
CONCRETE BLOCK
N.T.S.

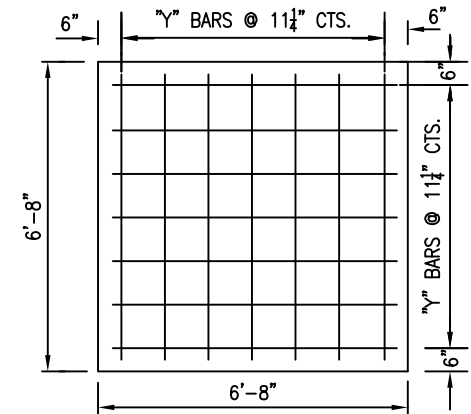

PLAN OF BASE SLAB

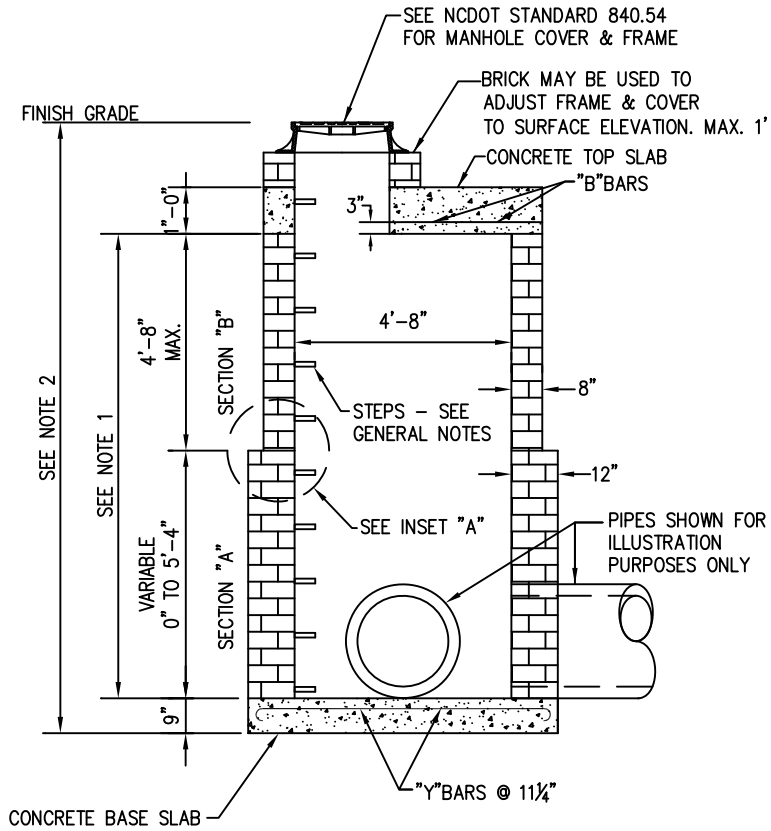

SECTION X-X
(WITH TOP)

Fayetteville
North Carolina

ENGINEERING DIVISION
433 HAY ST. 28301
(910) 433-1656
<http://www.fayettevillenc.gov>

**STANDARD TRAFFIC BEARING
JUNCTION BOX - 42" AND UNDER PIPES
NCDOT STANDARD # 840.34
SHEET 1 OF 2**

Rev. Date: 16JAN18
Not to Scale

DR-6

GENERAL NOTES:

STANDARD OR JUMBO BRICK SHALL BE USED FOR WALL CONSTRUCTION. SOLID CONCRETE BRICK OR BLOCK ARE OPTIONAL WALL CONSTRUCTION MATERIAL.

PRECAST UNITS MADE OF CLASS "AA" CONCRETE MAY BE USED IN LIEU OF BRICK MASONRY CONSTRUCTION. DESIGN OF PRECAST UNITS SHALL BE SUBMITTED FOR APPROVAL PRIOR TO CONSTRUCTION.

ALL ADJUSTMENTS TO WALLS, SLABS OR REINFORCING MATERIAL SHALL BE INCLUDED IN THE UNIT PRICE BID FOR EACH UNIT.

OPTIONAL MANHOLE SHALL BE INSTALLED IN POSITION AS DIRECTED BY THE ENGINEER. ALL REBAR CROSSING THIS OPENING SHALL BE CUT OR BENT TO ALLOW 2" MINIMUM CONCRETE COVERAGE. THE OPENING SHALL BE ENCLOSED WITH 8 "A" BARS TIED TO THE REBAR MAT AND SET SO A MINIMUM OF A 3" CONCRETE COVERAGE IS OBTAINED. REFERENCE NCDOT STD. NO. 840.54 FOR ALL MANHOLE INFORMATION.

JUNCTION BOXES OVER 3'-6" IN DEPTH WITH MANHOLES SHALL REQUIRE STEPS TO BE PLACED ON 12" - 16" CENTERS. REFERENCE NCDOT STD. NO. 840.66.

DOWEL "C" BARS SHALL BE SPACED AT A MINIMUM OF 12" CENTERS.

MAXIMUM DEPTH OF THIS UNIT AS SHOWN IS 12'.

BILL OF MATERIALS				
BAR	QTY.	SIZE	LENGTH	WEIGHT
A	8	#5	1'-2"	9.7
B	14	#5	5'-6"	80.3
C	26	#4	1'-6"	26.1
Y	14	#5	6'-11 3/8"	101.5
STEEL TOTAL WEIGHT				217.6
CU. YDS. CLASS "AA" CONC.				2.6
CU. YDS. BRICK/FT. HT. (8")				0.53
CU. YDS. BRICK/FT. HT. (12")				0.84

- NOTE 1: SECTION "B" OF THE PROPOSED WALL SHALL BE 8" THICK. SECTION "A" SHALL BE 12" THICK.
- NOTE 2: IF PROPOSED STRUCTURE EXCEEDS 12'-0" VERTICAL HEIGHT A DESIGN WILL BE REQUIRED FOR APPROVAL.
- NOTE 3: ALL REINFORCING STEEL SHALL BE SINGLE MAT; EXCEPT DOUBLE MAT STEEL MAY BE USED IN LIEU OF HOOK BARS IN BASE SLAB.



ENGINEERING DIVISION
433 HAY ST. 28301
(910) 433-1656
<http://www.fayettevillenc.gov>

STANDARD TRAFFIC BEARING
JUNCTION BOX - 42" AND UNDER PIPES
NCDOT STANDARD # 840.34
SHEET 2 OF 2

Rev. Date: 16JAN18
Not to Scale

DR-6.1

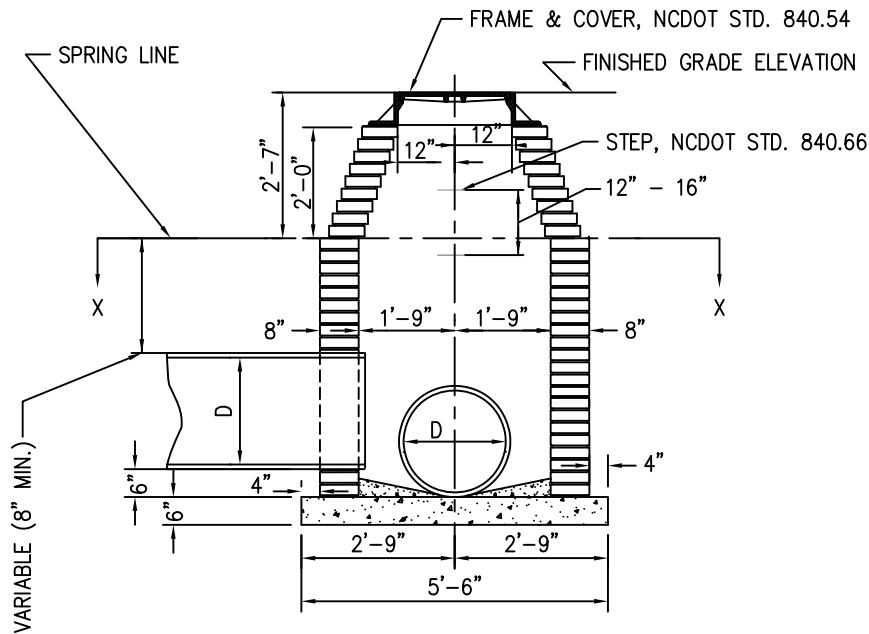

SECTION ON G

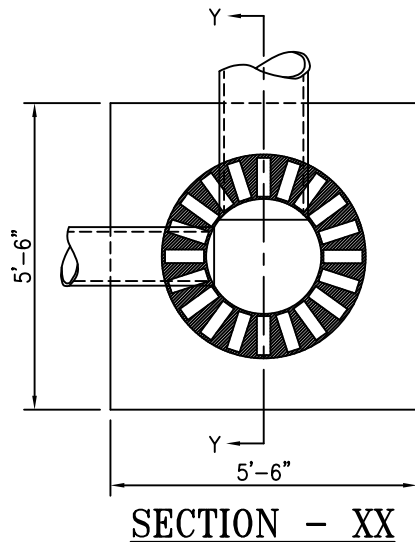

SECTION - XX

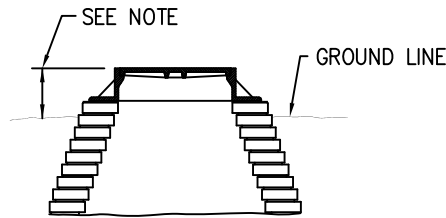

PART SECTION - YY

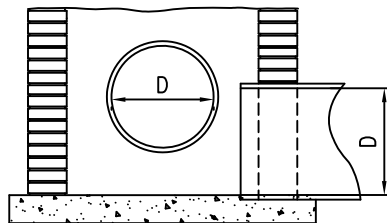

GENERAL NOTES:

- ALL MORTAR JOINTS ARE TO BE $1/2" \pm 1/8"$.
- ALL EXPOSED JOINTS WILL BE CONCAVE TOOLED.
- 3000 PSI CONCRETE TO BE USED.
- THE POURING OF FLOOR SLAB TO BE ACCOMPLISHED BY FORMING.
- JUMBO BRICK WILL BE PERMITTED. CONCRETE BRICK OR 4" SOLID CONCRETE BLOCKS MAY BE USED IN LIEU OF CLAY BRICK.
- IF REINFORCED CONCRETE PIPE IS SET IN BASE SLAB OF BOX, ADD TO BASE AS SHOWN ON STANDARD DR-9.
- WHERE THE MANHOLE IS EXPOSED TO ROAD TRAFFIC, THE TOP OF THE MANHOLE IS TO BE FLUSH WITH THE GROUND. AT OTHER LOCATIONS, IT SHOULD BE A MINIMUM OF 9" ABOVE THE GROUND.
- MANHOLES OVER 3'-6" IN DEPTH SHALL BE PROVIDED WITH STEPS 12" - 16" ON CENTERS. STEPS SHALL BE IN ACCORDANCE WITH NCDOT STD. 840.66.
- FOR 8' HEIGHT OR LESS USE 8" WALL. OVER 8' HEIGHT USE 12" WALL TO 6' FROM TOP OF WALL, 8" WALL FOR REMAINING 6'.
- INVERTS SHALL BE SHAPED TO FORM A SMOOTH, REGULAR SURFACE, SLOPED TO PREVENT SEDIMENTATION.

MIN. DIMENSIONS & QUANTITIES FOR MANHOLE					
PIPE DIM	CU. YDS. CONC.	TOTAL BRICK MASONRY CU. YDS.	CU YDS BRICK MASONRY PER FT. HT.	DEDUCTIONS FOR ONE PIPE (CU YDS)	
				C. M.	R. C.
D	BASE	ABOVE S-L	BELOW S-L		
	0.560	0.530	0.323		
15"	/	/	/	0.031	0.047
18"	/	/	/	0.044	0.065
24"	/	/	/	0.078	0.113
30"	/	/	/	0.122	0.170
36"	0.560	0.530	0.323	0.176	0.238

Fayetteville
North Carolina

ENGINEERING DIVISION
433 HAY ST. 28301
(910) 433-1656
<http://www.fayettevillenc.gov>

**STANDARD BRICK MANHOLE
12" THRU 36" PIPE
ADOPTED FROM N.C.D.O.T.
STANDARD NO. 840.51**

Rev. Date: 16JAN18
Not to Scale

DR-7

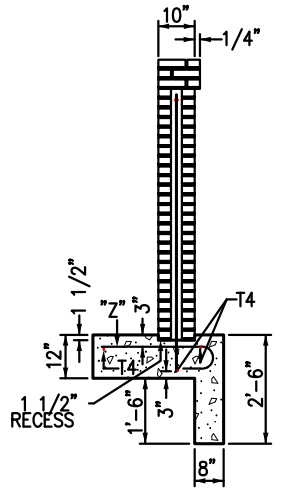

SECTION A-A

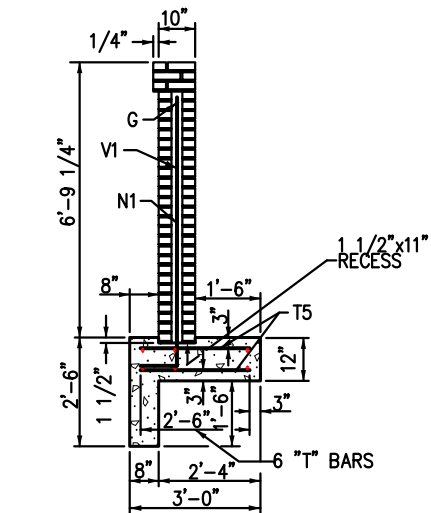

SECTION B-B

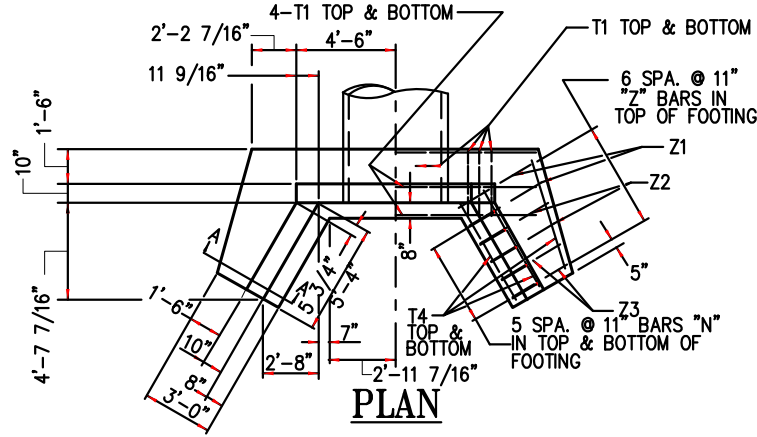

PLAN

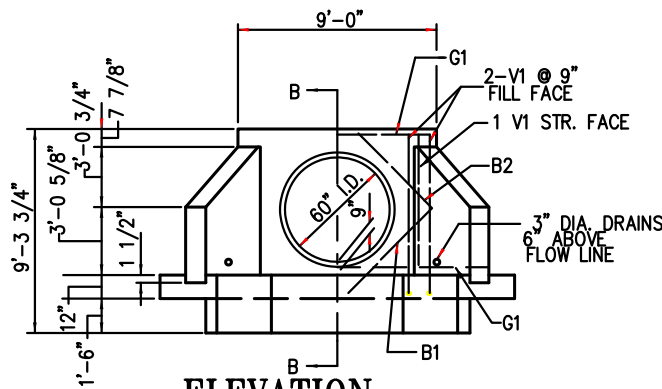

ELEVATION

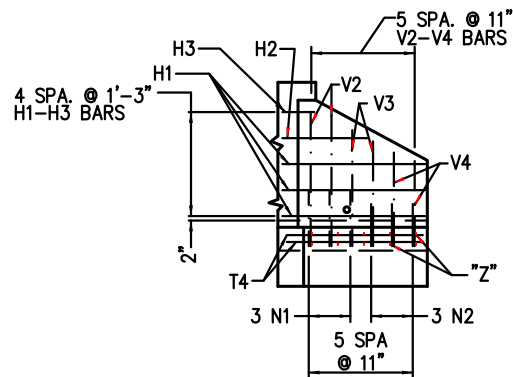

WING ELEVATION

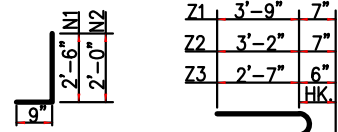

"N" BARS "Z" BARS
"N" & "Z" BAR DIMENSIONS ARE OUT TO OUT.

*PAY FOR CONCRETE AS BRICK MASONRY

BILL OF MATERIAL FOR ENDWALL				
BAR	SIZE	LENGTH	NO.	WEIGHT
B1	#5	5'-3"	2	11
B2	#5	3'-9"	2	8
G1	#7	8'-0"	2	33
H1	#4	5'-9"	6	23
H2	#4	4'-0"	2	5
H3	#4	2'-1"	2	3
N1	#5	3'-3"	12	41
N2	#4	2'-9"	6	11
T1	#4	13'-0"	6	52
T4	#4	5'-8"	6	23
T5	#4	2'-6"	36	60
V1	#4	6'-4"	6	25
V2	#4	5'-2"	4	14
V3	#4	3'-11"	4	10
V4	#4	2'-9"	4	7
Z1	#5	4'-4"	6	27
Z2	#5	3'-9"	4	16
Z3	#5	3'-1"	4	8
REINF. STEEL LBS.			377	
*CL. "A" CONC. FOOT. C.Y.				3.1
BR. MASONRY/C.S. C.Y.				2.8
BR. MASONRY/R.C. C.Y.				2.6

SEE NCDOT STD. DWG. NO. 838.75 FOR GENERAL NOTES.

Fayetteville
North Carolina

ENGINEERING DIVISION
433 HAY ST. 28301
(910) 433-1656
<http://www.fayettevillenc.gov>

**REINFORCED BRICK ENDWALL
ADOPTED FROM NCDOT
STANDARD NO. 838.57**

Rev. Date: 16JAN18
Not to Scale

DR-8

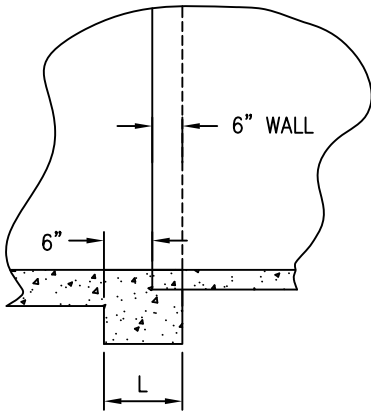

PART SECTION

6" WALL

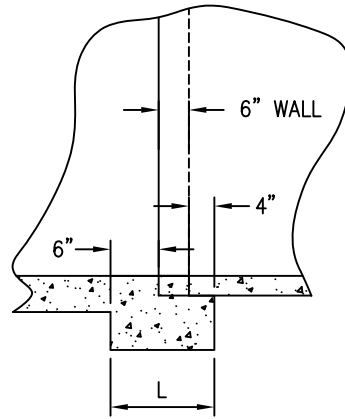

PART SECTION

6" WALL WITH 4" LIP

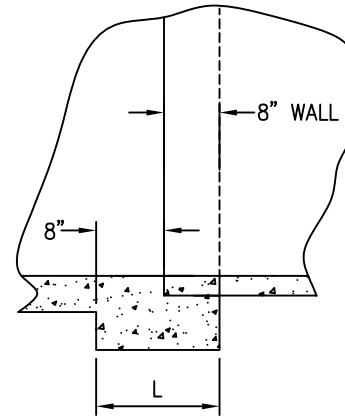

PART SECTION

8" WALL

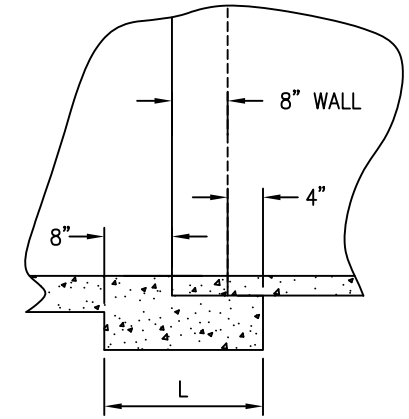

PART SECTION

8" WALL WITH 4" LIP

TABLES OF QUANTITIES FOR PIPE SET IN PAD						
PIPE D	"W" DIM	"W1" DIM	"T" DIM	C.Y. QUANTITIES WHEN "L" IS		
				12"	16"	20"
15"	1'-3 5/8"	0'-9 1/8"	0'-2"	0.006	0.008	0.010
18"	1'-5 1/4"	0'-10 3/8"	0'-2"	0.007	0.010	0.012
24"	1'-8 3/4"	1'-0 1/8"	0'-3"	0.011	0.014	0.018
30"	2'-0 1/4"	1'-2 3/4"	0'-3 1/2"	0.014	0.018	0.023
36"	2'-3 3/4"	1'-5 3/8"	0'-4"	0.017	0.023	0.025
42"	2'-7 1/8"	1'-7"	0'-5 1/4"	0.025	0.030	0.038
48"	2'-10 5/8"	1'-8 3/4"	0'-5 3/4"	0.028	0.038	0.047
54"	3'-2 1/8"	1'-10 1/2"	0'-6 1/4"	0.035	0.047	0.058
60"	3'-5 5/8"	2'-0 1/4"	0'-6 3/4"	0.042	0.056	0.071
66"	3'-9"	2'-2 1/4"	0'-7 1/4"	0.050	0.067	0.084
72"	4'-0 1/2"	2'-3 3/4"	0'-7 3/4"	0.059	0.078	0.098

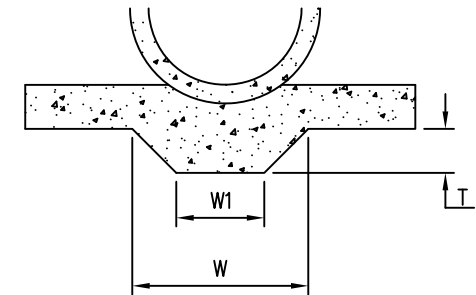

PART SECTION

OF END ELEVATION

GENERAL NOTES:

THIS STANDARD SHALL BE USED WITH ALL DRAINAGE STRUCTURES
USING REINFORCED CONCRETE PIPE SET IN BASE SLAB.

Fayetteville
North Carolina

ENGINEERING DIVISION
433 HAY ST. 28301
(910) 433-1656
<http://www.fayettevillenc.gov>

CONCRETE BASE PAD FOR
FOR DRAINAGE STRUCTURES
ADOPTED FROM NCDOT
STANDARD NO. 840.00

Rev. Date: 16JAN18
Not to Scale

DR-9

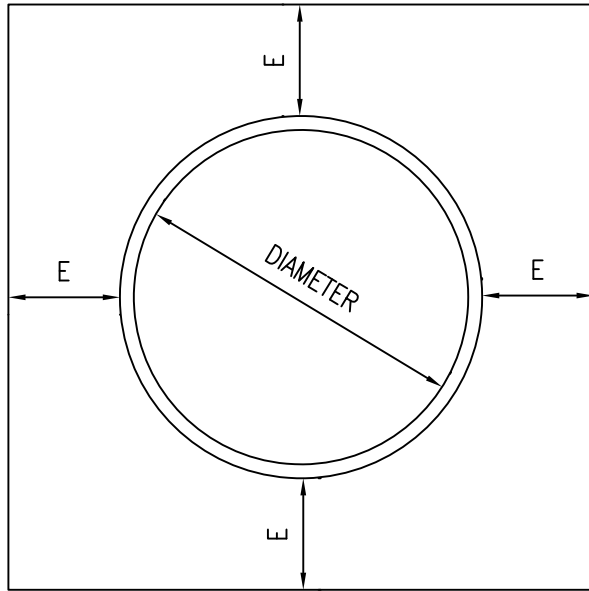

ELEVATION

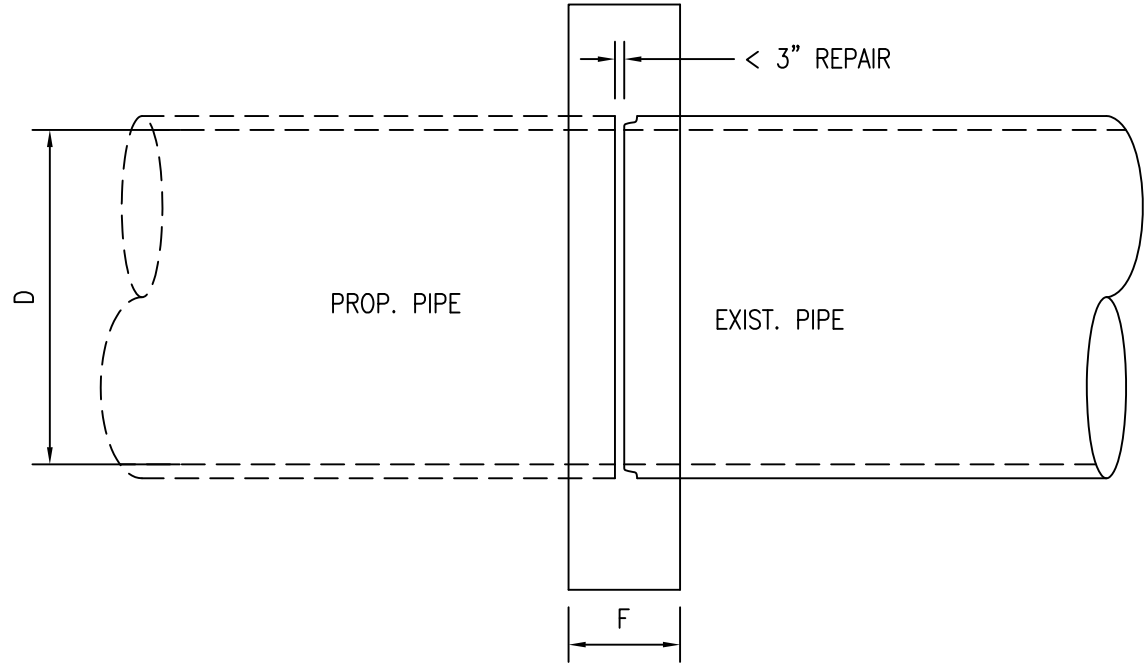

SIDE ELEVATION

GENERAL NOTES:

- 1) DIMENSION "F" SHALL BE 12" + WIDTH OF DAMAGE.
- 2) EXISTING PIPE REMOVED SHALL BE REPLACED WITH NEW RCP.
- 3) COLLARS NOT TO BE USED IF DAMAGE IS 16' OR CLOSER TO EXISTING STRUCTURE. IF DAMAGE IS THIS CLOSE NEW PIPE TO BE RELAID TO NEAREST STRUCTURE.
- 4) ALL WORK TO BE INSPECTED BY SENIOR ENGINEER OR DESIGNATE PRIOR TO CONCRETE PLACEMENT.
- 5) CONSTRUCT COLLAR WITH FORMED 3000 PSI CONCRETE WITH AIR ENTRAINMENT.
- 6) DAMAGED PIPE WITH MORE THAN 3" OF DAMAGE SHALL BE REPLACED WITH NEW PIPE.
- 7) METAL FLASHING SHALL BE USED TO SEAL JOINT PRIOR TO CONCRETE PLACEMENT. GAP AT JOINT MAY NOT EXCEED 3".

D	E	F	CU. YD.
15"	8"	12"+	.03990
18"	8"	12"+	0.4465
24"	12"	12"+	0.5526
30"	12"	12"+	0.6560
36"	12"	12"+	0.7640
42"	12"	12"+	0.8856
48"	12"	12"+	1.0126
54"	18"	18"+	2.5793
60"	18"	18"+	2.8506
66"	18"	18"+	3.1307
72"	18"	18"+	3.4176



ENGINEERING DIVISION
 433 HAY ST. 28301
 (910) 433-1656
<http://www.fayettevillenc.gov>

CONCRETE PIPE COLLAR FOR
 FOR REPAIRING STORM DRAINS
 ADOPTED FROM NCDOT
 STANDARD NO. 840.00

Rev. Date: 16JAN18
 Not to Scale

DR-10

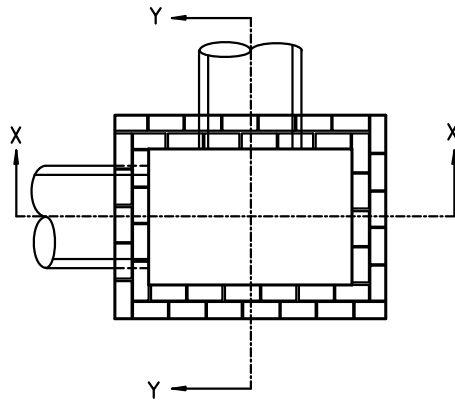

PLAN

WITH COPING REMOVED

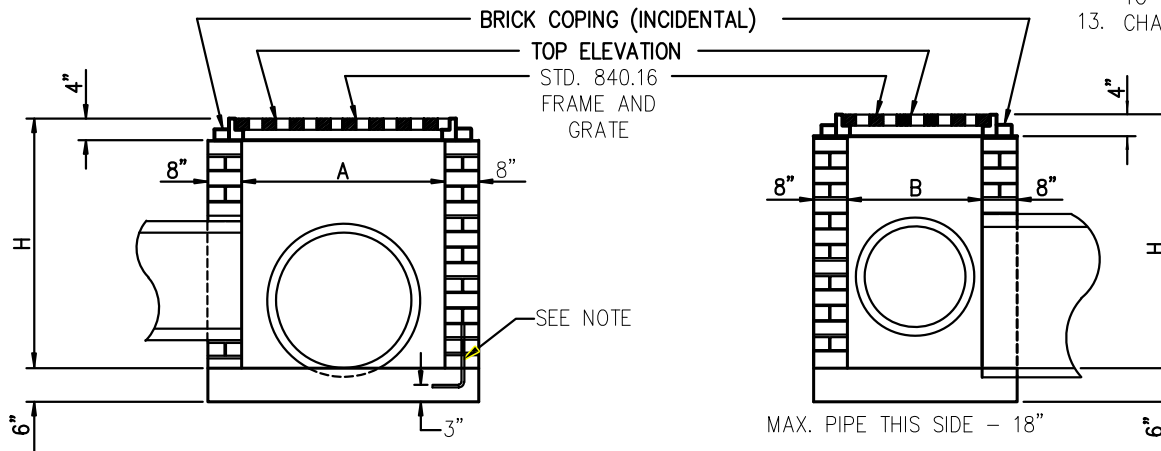

SECTION X-X

SECTION Y-Y

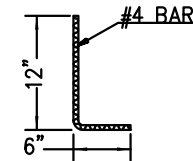

DOWEL

GENERAL NOTES:

1. MORTAR JOINTS 1/2" +/- 1/8" THICK.
2. USE CLASS "B" CONCRETE THROUGHOUT.
3. USE FORMS FOR CONSTRUCTION OF THE BOTTOM SLAB.
4. USE #4 BAR DOWELS AT 12" CENTERS.
5. DEDUCT FOR PIPE(S) FROM TOTAL CU. YDS. OF BRICK MASONRY.
6. PROVIDE ALL CATCH BASINS OVER 3'-6" IN DEPTH WITH STEPS 12" ON CENTER. USE STEPS WHICH COMPLY WITH STD. DRAWING 840.66.
7. USE BRICK OR CONCRETE BLOCK WHICH COMPLIES WITH THE REQUIREMENTS OF SECTION 840 OF THE STANDARD SPECIFICATIONS.
8. IF REINFORCED CONCRETE PIPE IS SET IN BOTTOM SLAB OF BOX, ADD TO SLAB AS SHOWN ON STD. NO. 840.00.
9. FOR 8'-0" IN HEIGHT OR LESS, USE 8" WALL. OVER 8'-0" IN HEIGHT, USE 12" WALL TO 6'-0" FROM TOP OF WALL AND 8" WALL FOR THE UPPER 6'-0". QUANTITIES TO BE ADJUSTED ACCORDINGLY.
10. CONSTRUCT WITH PIPE CROWNS MATCHING.
11. SEE NCDOT STANDARD DRAWING 840.25 FOR ATTACHMENT OF FRAMES AND GRATES.
12. DO NOT USE BRICK MASONRY DROP INLET IN LOCATIONS SUBJECT TO TRAFFIC.
13. CHAMFER ALL EXPOSED CORNERS 1".

DIMENSIONS AND QUANTITIES FOR DROP INLET(BASED ON MIN. HEIGHT, H)									
DIMENSIONS OF BOX & PIPE				CUBIC YARDS CONCRETE	CUBIC YARDS BRICK MASONRY		DEDUCTIONS FOR ONE PIPE		
PIPE	SPAN	WIDTH	MIN. HEIGHT		WALL PER FOOT HT.	TOTAL BRICK MASONRY FOR MIN. HEIGHT, H	C.S.	R.C.	
D	A	B	H	BOTTOM SLAB					
12"	3'-0"	2'-0"	2'-0"	0.268	0.313	0.522	0.020	0.032	
15"	↗	↗	2'-3"	0.268	0.313	0.600	0.031	0.047	
18"	↗	↗	2'-6"	0.268	0.313	0.678	0.044	0.065	
24"	↗	↗	3'-0"	0.268	0.313	0.835	0.078	0.113	
30"	3'-0"	2'-0"	3'-6"	0.268	0.313	0.991	0.122	0.170	



ENGINEERING DIVISION
 433 HAY ST. 28301
 (910) 433-1656
<http://www.fayettevillenc.gov>

DROP INLET WITH GRATE
 12" TO 30" PIPE
 NCDOT STANDARD NO. 840.15

Rev. Date: 16JAN18
 Not to Scale

DR-11

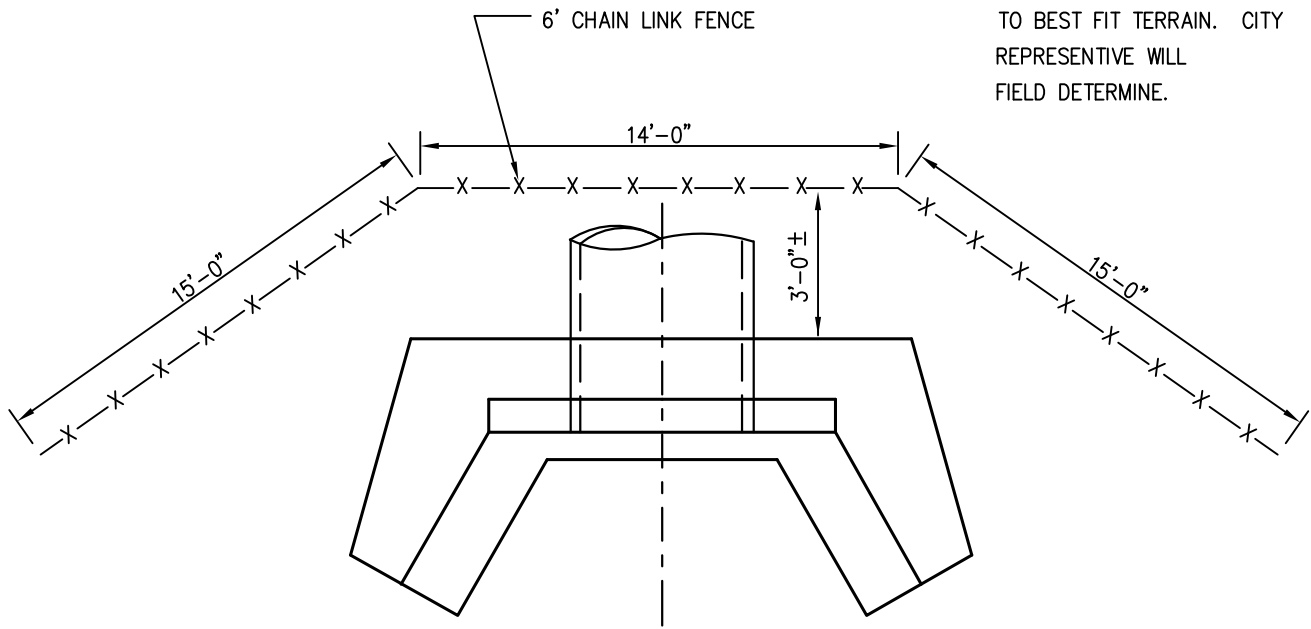

DIMENSIONS MAY BE MODIFIED
TO BEST FIT TERRAIN. CITY
REPRESENTATIVE WILL
FIELD DETERMINE.

Fayetteville
North Carolina

ENGINEERING DIVISION
433 HAY ST. 28301
(910) 433-1656
<http://www.fayettevillenc.gov>

FENCE PLAN
AT ENDWALL

Rev. Date: 16JAN18
Not to Scale

DR-12

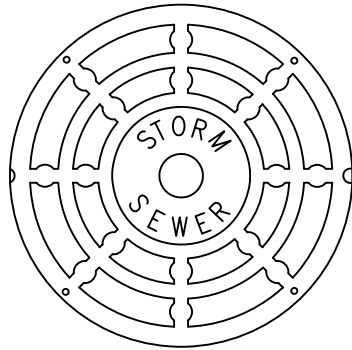

TOP OF MANHOLE

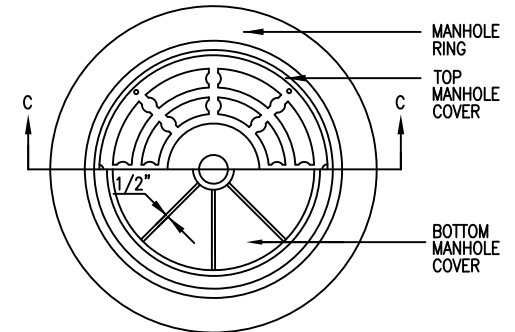

SPECIFICATIONS

1. MANHOLE RING AND COVER TO BE MADE OF GREY CAST IRON CONFORMING TO ASTM SPECIFICATIONS A 48-74, CLASS 30. ALL CASTINGS SHALL CONFORM TO THE SHAPE AND DIMENSIONS SHOWN. THEY SHALL BE CLEAN AND PERFECT WITHOUT BLOW OR SANDHOLES OR DEFECTS OF ANY KIND, TENDING TO IMPAIR THEIR STRENGTH. NO PLUGGING OR STOPPING OF DEFECTIVE HOLES WILL BE PERMITTED.
2. MANHOLE RING AND COVER TO WITHSTAND VEHICULAR TRAFFIC WITHOUT OBJECTIONABLE NOISE.
3. MINIMUM AVERAGE WEIGHT:

FRAME: 180 LBS
COVER: 120 LBS

US FOUNDRY 669-KL RING & COVER
OR APPROVED EQUAL

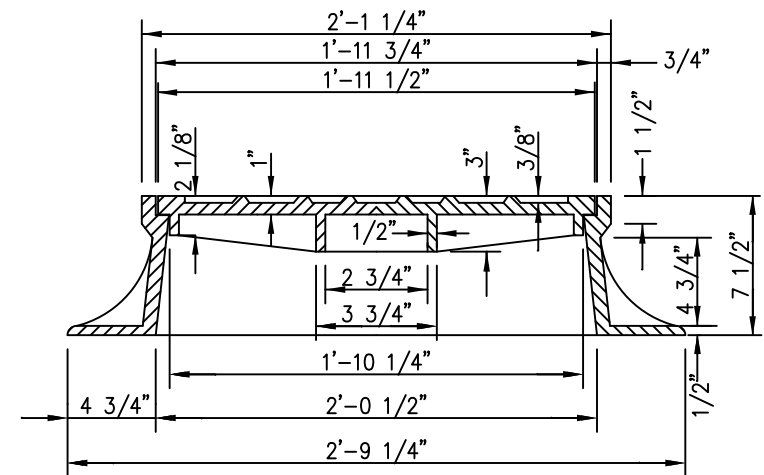

SECTION C - C

Fayetteville
North Carolina

ENGINEERING DIVISION
433 HAY ST. 28301
(910) 433-1656
<http://www.fayettevillenc.gov>

STANDARD MANHOLE RING AND COVER
ADOPTED FROM NCDOT
STANDARD NO. 840.54

Rev. Date: 16JAN18
Not to Scale

DR-13

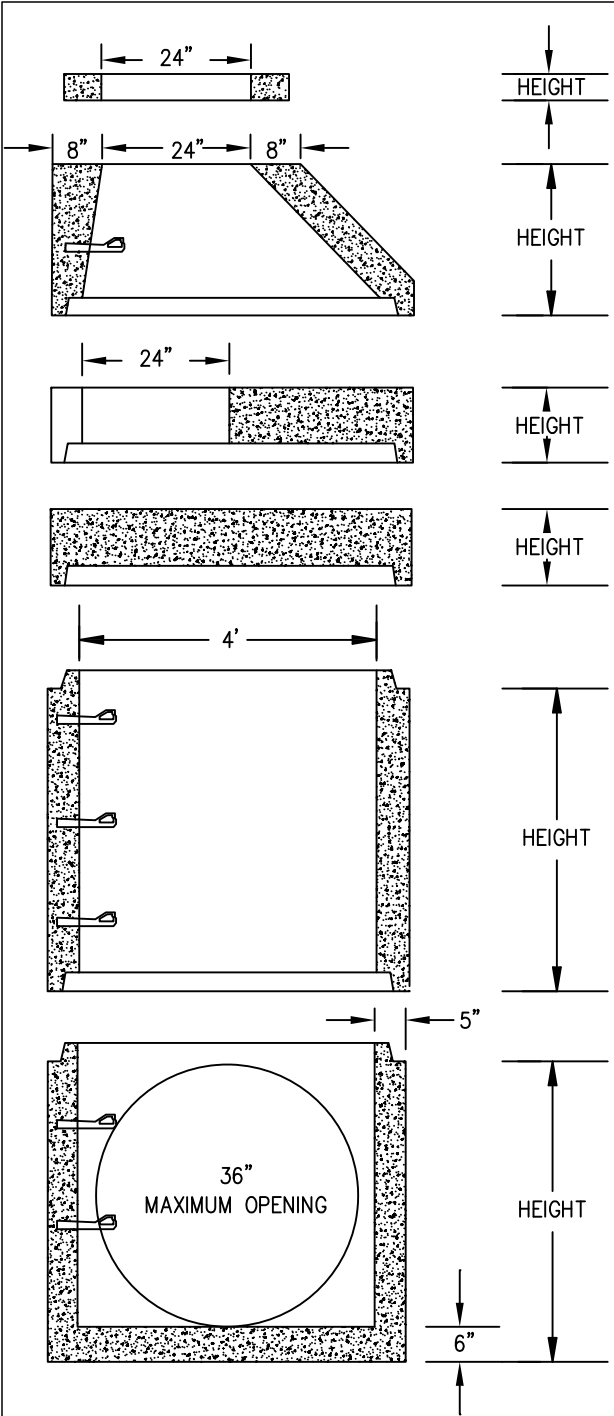

FUQUAY VARINA PLANT SPECIFICATIONS:

ASTM C 478 – LATEST
 AASHTO M 199 – LATEST

WITH AASHTO M-198B PREFORMED PLASTIC OR ASTM C-443 RUBBER GASKET JOINTS. REINFORCED IN ACCORDANCE WITH APPLICABLE SPECIFICATIONS.

<u>HEIGHT</u>		<u>WEIGHT</u>	<u>SOLID FLAT TOP</u>		
<u>FEET</u>	<u>INCHES</u>	<u>POUNDS</u>	CUSTOM VENT OR METER OPENINGS PLACED PER CUSTOMER REQUEST. FLAT TOPS MEET H-20 LOADING.		
<u>GRADING RING</u>					
.33'	4"	150	1.00'	12"	2000
.50'	6"	235			
<u>ECCENTRIC CONE</u>					
			<u>RISER</u>		
2.00'	24"	1695	1.00'	12"	865
3.00'	36"	2550	1.33'	16"	1150
4.00'	48"	3400	2.67'	32"	2310
			4.00'	48"	3460
			5.33'	64"	4610
<u>FLAT TOP</u>					
FLAT TOPS ARE AVAILABLE IN ECCENTRIC (AS SHOWN) AND CONCENTRIC UNITS. FLAT TOPS MEET H-20 LOADING.					
1.00'	12"	1700	<u>REGULAR MONOLITHIC BASE</u> WITH 6" BASE INCLUDED IN HEIGHT SHOWN.		
			2.67'	32"	3250
			4.00'	48"	4400
			5.33'	60"	5265

NOTES:

1. PRECAST MANHOLES MAY BE USED WITH PRIOR APPROVAL FROM THE CITY ENGINEER.
2. PRECAST MANHOLES ARE NOT PERMITTED INSIDE RIGHT-OF-WAY OR EASEMENTS.

Fayetteville
North Carolina

ENGINEERING DIVISION
 433 HAY ST. 28301
 (910) 433-1656
<http://www.fayettevillenc.gov>

4-FOOT DIAMETER PRECAST REINFORCED CONCRETE MANHOLE SECTIONS

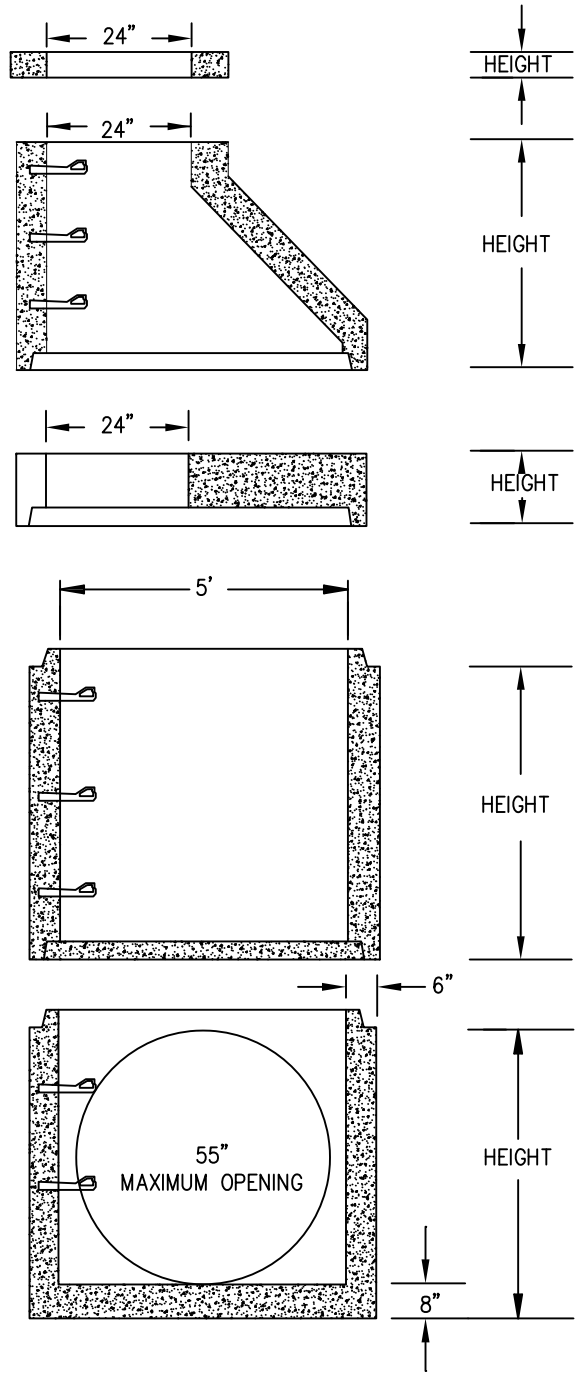

FUQUAY VARINA PLANT SPECIFICATIONS:

ASTM C 478 – LATEST
 AASHTO M 199 – LATEST

WITH AASHTO M-198B PREFORMED PLASTIC OR ASTM C-443 RUBBER GASKET JOINTS. REINFORCED IN ACCORDANCE WITH APPLICABLE SPECIFICATIONS.

<u>HEIGHT</u>		<u>WEIGHT</u> POUNDS	<u>RISER</u>	
<u>FEET</u>	<u>INCHES</u>			
<u>GRADING RING</u>				
.33'	4"	150	12"	1290
.50'	6"	235	16"	1716
			32"	3444
			48"	5160

REGULAR MONOLITHIC BASE

WITH 8" BASE INCLUDED IN HEIGHT SHOWN.

<u>ECCENTRIC CONE</u>		<u>WEIGHT</u> POUNDS	<u>RISER</u>	
<u>FEET</u>	<u>INCHES</u>			
4.00'	48"	4360	32"	5394
			36"	5820
			40"	6245
			44"	6684
			48"	7110
			52"	7535
			56"	7974
			60"	8400
			64"	8825
			68"	9264
			72"	9690
			76"	10115
			80"	10554

FLAT TOP

FLAT TOPS ARE AVAILABLE IN ECCENTRIC (AS SHOWN) AND CONCENTRIC UNITS. FLAT TOPS MEET H-20 LOADING.

1.00'	12"	2825
-------	-----	------

NOTES:

1. PRECAST MANHOLES MAY BE USED WITH PRIOR APPROVAL FROM THE CITY ENGINEER.
2. PRECAST MANHOLES ARE NOT PERMITTED INSIDE RIGHT-OF-WAY OR EASEMENTS.



ENGINEERING DIVISION
 433 HAY ST. 28301
 (910) 433-1656
<http://www.fayettevillenc.gov>

5-FOOT DIAMETER PRECAST REINFORCED CONCRETE MANHOLE SECTIONS

Rev. Date: 16JAN18
 Not to Scale

DR-14.1

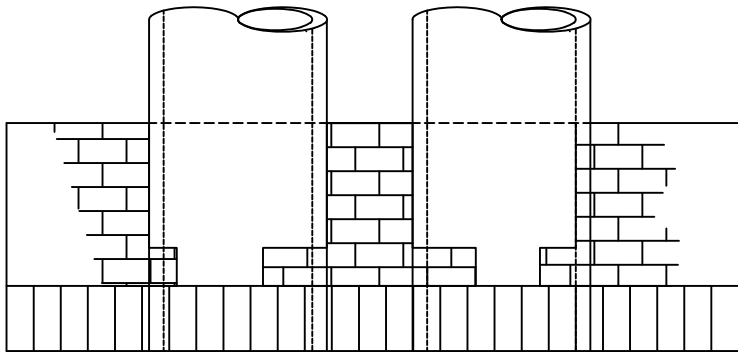

PLAN

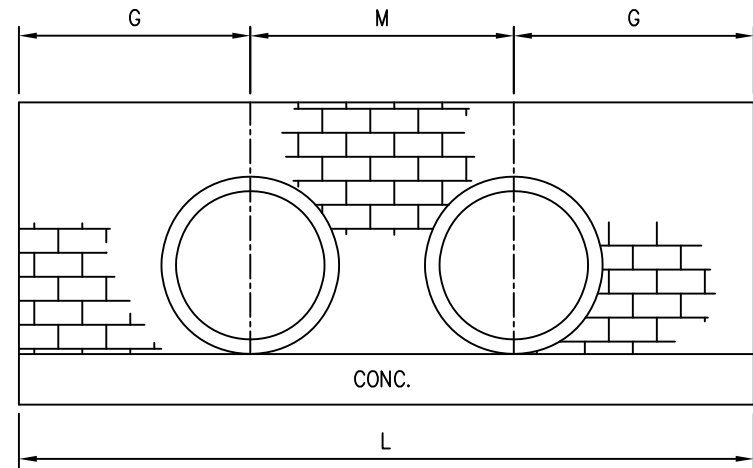

ELEVATION

SLOPE AS INDICATED ON PLANS

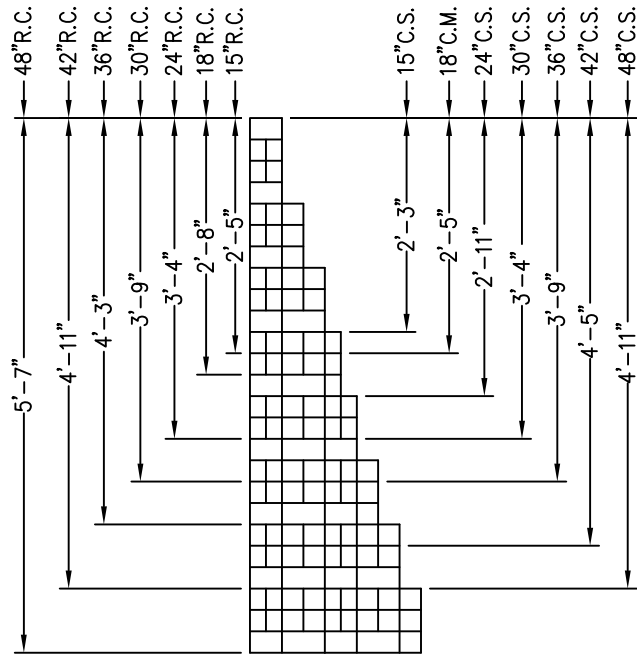

TYPICAL SECTION
THRU WALL

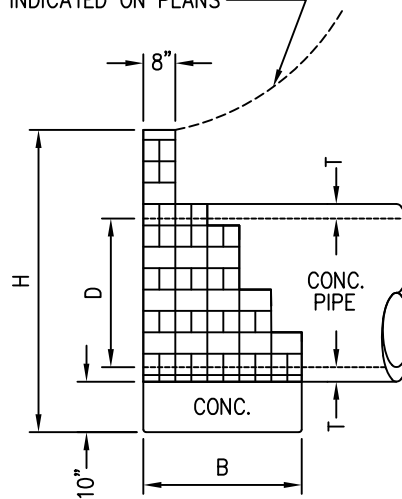

END ELEVATION

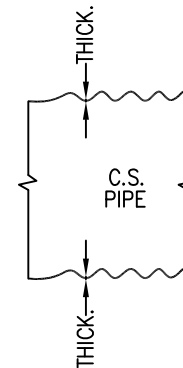

Fayetteville
North Carolina

ENGINEERING DIVISION
433 HAY ST. 28301
(910) 433-1656
<http://www.fayettevillenc.gov>

STANDARD MASONRY ENDWALL FOR
SINGLE & DOUBLE PIPE CULVERTS
(15"-48" PIPE) 90° SKEW; NCDOT STD 838.11
PAGE 1 OF 2

Rev. Date: 16JAN18
Not to Scale

DR-15

DIMENSIONS AND QUANTITIES																							
USING CONCRETE PIPE											USING CORRUGATED METAL PIPE												
COMMON DIMS.					SINGLE PIPE				DOUBLE PIPE				COMMON DIMS.					SINGLE PIPE			DOUBLE PIPE		
D	H	B	G	T	L	BRICK YD ³	CONC. YD ³	M	L	BRICK YD ³	CONC. YD ³	D	H	B	G	L	L	BRICK YD ³	CONC. YD ³	M	L	BRICK YD ³	CONC. YD ³
15"	2'-5"	1'-8"	2'-10"	1 7/8"	5'-8"	0.441	0.291	2'-2"	7'-10"	0.555	0.403	15"	2'-3"	1'-4"	2'-9"	5'-6"	5'-6"	0.384	0.226	1'-11"	7'-5"	0.482	0.305
18"	2'-8"	1'-8"	3'-2"	2"	6'-4"	0.562	0.326	2'-7"	8'-11"	0.722	0.459	18"	2'-5"	1'-8"	3'-0"	6'-0"	6'-0"	0.478	0.309	2'-3"	8'-3"	0.605	0.424
24"	3'-4"	2'-0"	4'-1"	3"	8'-2"	1.008	0.504	3'-5"	11'-7"	1.285	0.715	24"	2'-11"	1'-8"	3'-9"	7'-6"	7'-6"	0.749	0.386	3'-0"	10'-6"	0.954	0.540
30"	3'-9"	2'-4"	4'-8"	3 1/2"	9'-4"	1.391	0.672	4'-3"	13'-7"	1.820	0.978	30"	3'-4"	2'-0"	4'-5"	8'-10"	8'-10"	1.090	0.545	3'-9"	12'-7"	1.399	0.777
36"	4'-3"	2'-4"	5'-5"	4"	10'-10"	1.895	0.780	5'-0"	15'-10"	2.462	1.140	36"	3'-9"	2'-4"	5'-0"	10'-0"	10'-0"	1.503	0.720	4'-6"	14'-6"	1.965	1.044
42"	4'-11"	2'-8"	6'-4"	5 1/4"	12'-8"	2.867	1.043	5'-10"	18'-6"	3.729	1.523	42"	4'-5"	2'-8"	6'-0"	12'-0"	12'-0"	2.373	0.988	5'-3"	17'-3"	3.062	1.420
48"	5'-7"	3'-0"	7'-3"	5 3/4"	14'-6"	4.032	1.343	6'-8"	21'-2"	5.184	1.960	48"	4'-11"	2'-8"	6'-9"	13'-6"	13'-6"	3.102	1.111	6'-0"	19'-6"	4.002	1.606

GENERAL NOTES:

ALL MORTAR JOINTS ARE 1/2" ± 1/8"

BRICKWORK SHALL BE BONDED WITH FULL HEADERS EVERY THREE COURSES.

ALL EXPOSED JOINTS SHALL BE CONCAVE TOOLED.

WALL THICKNESS (T) SHOWN IS NOT TO BE INTERPRETED TO MEAN THE THICKNESS ACCEPTABLE, BUT IS USED ONLY IN COMPUTING ENDWALL DIMENSIONS AND QUANTITIES.

FORMS ARE TO BE USED FOR THE CONSTRUCTION OF THE BASE.

CLASS 'A' CONCRETE SHALL BE USED.

CONCRETE BRICK MAY BE USED IN LIEU OF CLAY BRICK.

JUMBO BRICK WILL BE PERMITTED.



ENGINEERING DIVISION

433 HAY ST. 28301

(910) 433-1656

<http://www.fayettevillenc.gov>

**STANDARD MASONRY ENDWALL FOR
SINGLE & DOUBLE PIPE CULVERTS
(15"-48"PIPE)90° SKEW; NCDOT STD 838.11
PAGE 2 OF 2**

Rev. Date: 16JAN18
Not to Scale

DR-15.1

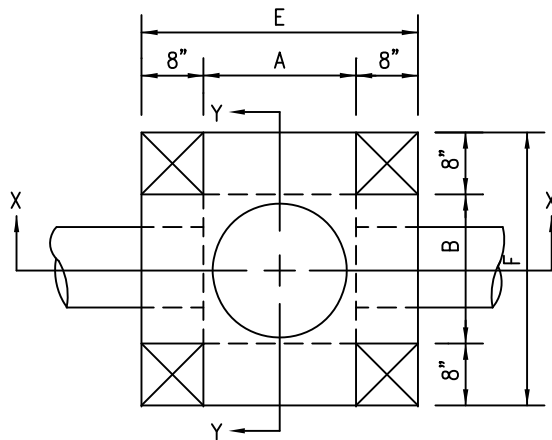

PLAN

GENERAL NOTES:

1. CONCRETE BASES TO BE CLASS "A" (3000 P.S.I.) PLACES ON A FIRM FOUNDATION.
2. FORMS ARE TO BE USED FOR THE CONSTRUCTION OF THE BOTTOM SLAB.
3. ALL MORTAR JOINTS ARE TO BE 1/2" +/- 1/8".
4. ALL EXPOSED JOINTS SHALL BE CONCAVE TOOLED.
5. CEMENT MORTAR SHALL BE ASTM C-270, TYPE "M".
6. JUMBO BRICK WILL BE PERMITTED. CONCRETE BRICK OR 4" SOLID CONCRETE BLOCKS MAY BE USED IN LIEU OF CLAY BRICK.
7. FOR 8'-0" IN HEIGHT OR LESS USE 8" WALL; OVER 8'-0" IN HEIGHT USE 12" WALL TO 6'-0" FORM TOP OF WALL, AND 8" WALL FOR THE REMAINING 6'-0".
8. ALL JUNCTION BOXES OVER 3'-6" IN DEPTH SHALL BE PROVIDED WITH STEPS 12" TO 16" ON CENTERS.
9. INVERTS SHALL BE SHAPED TO FORM A SMOOTH, REGULAR SURFACE, SLOPED TO PREVENT SEDIMENTATION.

DIMENSIONS AND QUANTITIES FOR BRICK JUNCTION BOXES												
DIM'S OF BOX & PIPE				REINFORCEMENT		COVER		CUBIC YARDS			DEDUCTIONS FOR ONE	
PIPE	SPAN	WIDTH	HEIGHT	BARS		DIMENSIONS		CONC.	BRICK	MASONRY	PIPE CU. YDS.	
D	A	B	H	NO.	LENGTH	E	F	BASE & COVER CU. YD.	MIN. HEIGHT CU. YD.	WALL PER FT. HT. CU. YD.	C.S.	R.C.
15"	2'-0"	2'-0"	2'-6"	12	3'-1"	3'-4"	3'-4"	0.412	0.657	0.263	0.031	0.047
18"	2'-4"	2'-4"	2'-9"	14	3'-5"	3'-8"	3'-8"	0.498	0.814	0.296	0.044	0.065
24"	3'-0"	3'-0"	3'-3"	16	4'-1"	4'-4"	4'-4"	0.695	1.176	0.362	0.078	0.113
30"	3'-4"	3'-4"	3'-9"	16	4'-5"	4'-8"	4'-8"	0.807	1.481	0.395	0.122	0.170
36"	4'-0"	4'-0"	4'-3"	20	5'-1"	5'-4"	5'-4"	1.053	1.959	0.461	0.176	0.238
42"	4'-8"	4'-8"	4'-9"	22	5'-9"	6'-0"	6'-0"	1.333	2.503	0.527	0.240	0.323
48"	5'-4"	5'-4"	5'-3"	26	6'-5"	6'-8"	6'-8"	1.646	2.940	0.560	0.313	0.422
54"	5'-10"	5'-10"	5'-9"	28	6'-11"	7'-2"	7'-2"	1.902	3.502	0.609	0.396	0.535
60"	6'-6"	6'-6"	6'-3"	30	7'-7"	7'-10"	7'-10"	2.272	4.113	0.658	0.489	0.660
66"	7'-1"	7'-1"	6'-9"	32	8'-2"	8'-5"	8'-5"	2.624	4.778	0.708	0.591	0.798

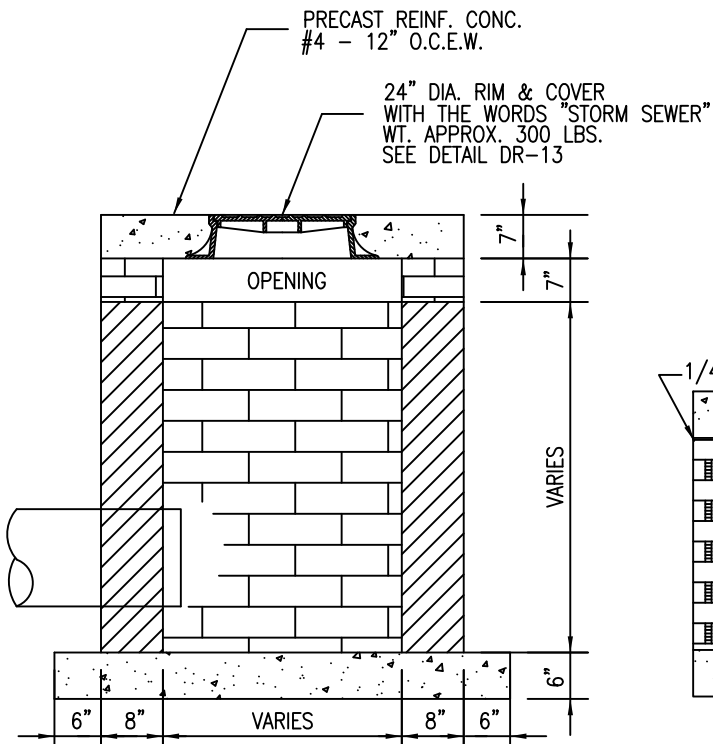

SECTION - XX

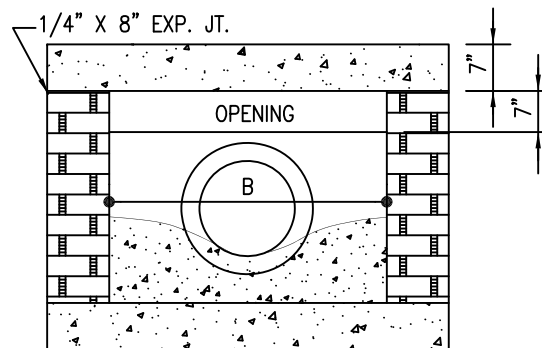

SECTION - YY



ENGINEERING DIVISION
433 HAY ST. 28301
(910) 433-1656
<http://www.fayettevillenc.gov>

**OPEN THROAT
JUNCTION BOX**

Rev. Date: 16JAN18
Not to Scale

DR-16

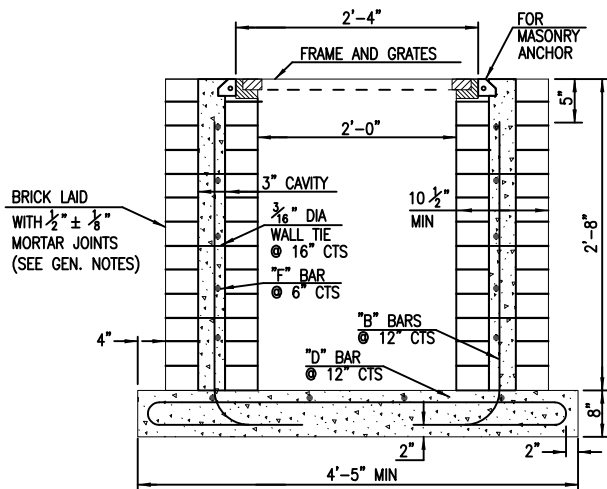

SECTION - XX

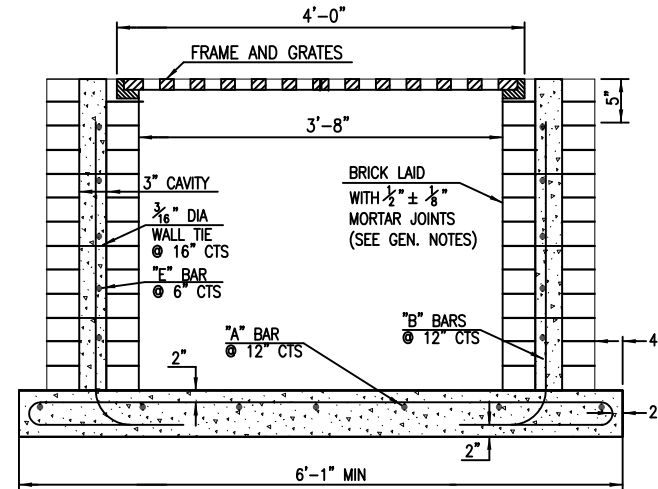

SECTION - YY

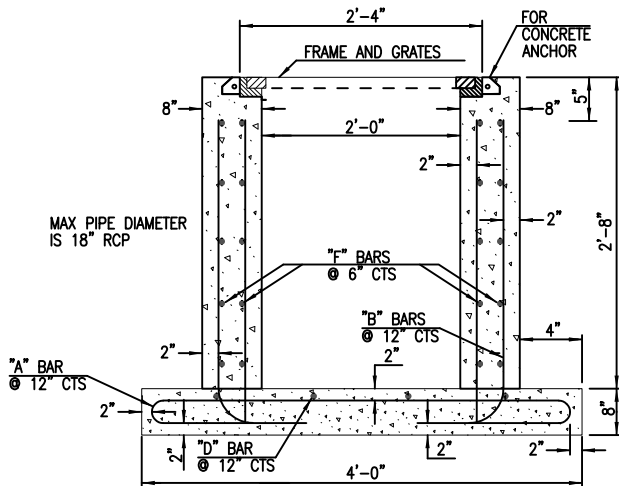

SECTION - XX

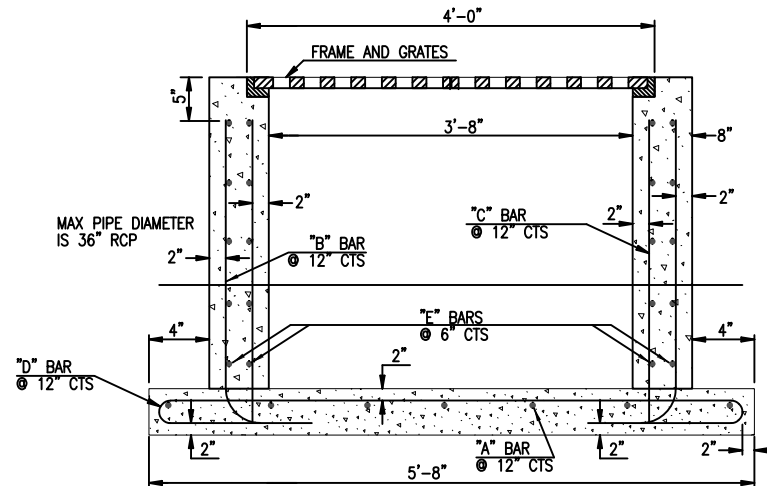

SECTION - YY

BRICK ALT.

CONCRETE ALT.

GENERAL NOTES:

1. HORIZONTAL AND VERTICAL DIMENSIONS MAY BE ADJUSTED AS THE FIELD CONDITIONS AND/OR ALTERNATE DESIGN REQUIRE.
2. MAXIMUM HEIGHT FOR THIS STRUCTURE IS 14'-0".
3. MAKE ALL ADJUSTMENTS AS DIRECTED BY THE ENGINEER.
4. DEPTH OF STEEL GRATE WILL REQUIRE DEEPER SEAT ALONG SHORT WALLS.

Fayetteville
North Carolina

ENGINEERING DIVISION
433 HAY ST. 28301
(910) 433-1656
<http://www.fayettevillenc.gov>

TRAFFIC BEARING DROP INLET
FOR CAST IRON DOUBLE FRAME AND GRATES
ADOPTED FROM NCDOT STANDARD # 840.35
SHEET 1 OF 2

Rev. Date: 16JAN18
Not to Scale

DR-17

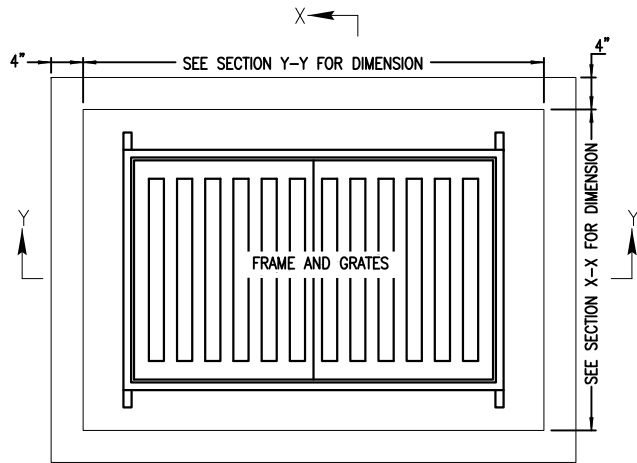

PLAN

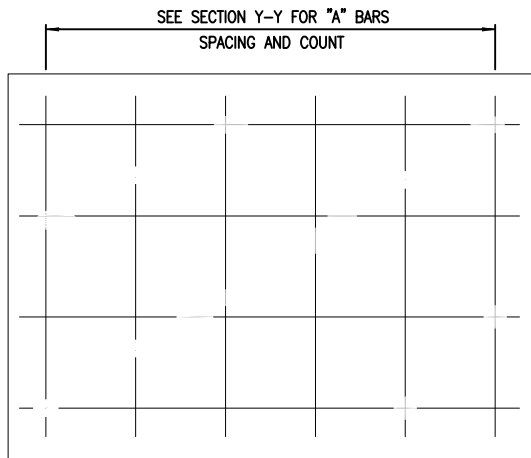

PLAN OF BASE

BILL OF MATERIALS							
COMMON		CONCRETE ALT.			BRICK ALT.		
BAR	SIZE	LENGTH	QUANTITY	WEIGHT	LENGTH	QUANTITY	WEIGHT
A	#5	6'-4½"	6	39.9	7'-7½"	6	47.7
B	#5	3'-4½"	16	56.3	3'-4½"	16	56.3
C	#5	2'-8"	14	38.9	0	0	0
D	#5	8'-0½"	4	33.6	9'-3½"	4	38.8
E	#5	3'-0"	20	62.6	3'-0"	10	31.3
F	#5	4'-8"	20	97.3	4'-8"	10	48.7
REINF STEEL (TOTAL WEIGHT LBS)				328.6			222.8
CONCRETE IN BASE CLASS 'AA' (CUBIC YARDS)				0.56			0.66
CONCRETE IN WALLS CLASS 'AA' (CUBIC YARDS)				0.92			0
CONCRETE IN WALLS CLASS 'B' (CUBIC YARDS)				0			0.36
BRICK IN WALLS (CUBIC YARDS)				0			0.91
CONCRETE TOTAL (CUBIC YARDS)				1.48			1.02
BRICK & CONCRETE TOTAL (CUBIC YARDS)				1.48			1.93
CONC CUBIC YARDS IN WALL/FOOT OF HEIGHT				0.35			0.14
BRICK CUBIC YARDS IN WALL/FOOT OF HEIGHT				0			0.34
LBS OF REINF STEEL IN WALL/FOOT OF HEIGHT				94.9			47.6

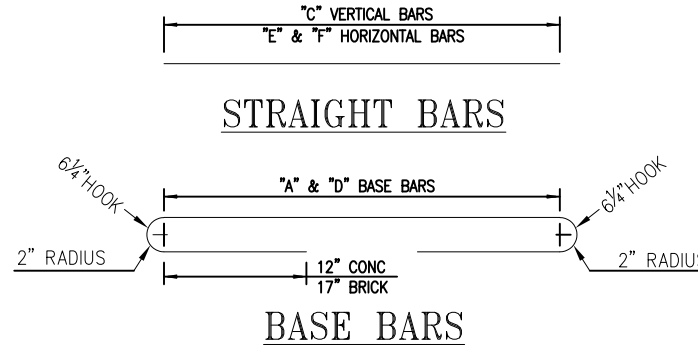

BASE BARS

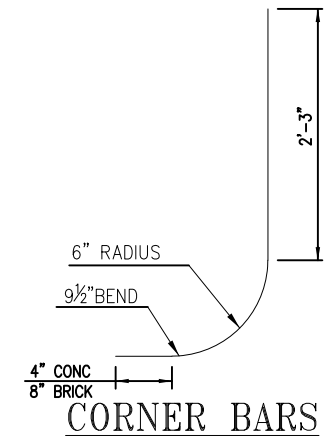

CORNER BARS

GENERAL NOTES:

1. USE CLASS "AA" CONCRETE FOR CAST IN PLACE CONCRETE BOX.
2. USE CLASS "B" CONCRETE IN THE WALL CAVITY FOR REINFORCED BRICK CONSTRUCTION AND CLASS "AA" FOR THE FOOTING BASE.
3. CHAMFER ALL EXPOSED CONCRETE CORNERS 1".
4. USE FORMS TO CONSTRUCT THE BOTTOM SLAB.
5. IF PIPES ARE SET IN THE BASE FOLLOW CONSTRUCTION PROCEDURES SHOWN BY STD DWG DR-9.
6. PRECAST UNITS MADE OF CLASS "AA" CONCRETE MAY BE USED IN LIEU OF BRICK MASONRY CONSTRUCTION.
7. INCLUDE REINFORCING STEEL COST IN THE UNIT OR LINEAR FOOT BID PRICE FOR "MASONRY DRAINAGE STRUCTURE".
8. REFERENCE NCDOT STD DWG 840.25 FOR FRAME ANCHORAGE.
9. CONCRETE BRICK, JUMBO BRICK AND 4" SOLID CONCRETE BLOCK WILL BE PERMITTED.
10. CONCRETE FOR BRICK BOX REFER TO SECTION 00455 OF THE STANDARD SPECIFICATIONS.
11. PROVIDE GRATED DROP INLETS OVER 3'-6" DEEP WITH STEPS SPACED 12" TO 16" ON CENTER.
12. FRAME AND GRATES ARE SEPARATE CONTRACT ITEMS.



ENGINEERING DIVISION
433 HAY ST. 28301
(910) 433-1656
<http://www.fayettevillenc.gov>

TRAFFIC BEARING DROP INLET
FOR CAST IRON DOUBLE FRAME AND GRATES
NCDOT STANDARD # 840.35
SHEET 2 OF 2

Rev. Date: 16JAN18
Not to Scale

DR-17.1

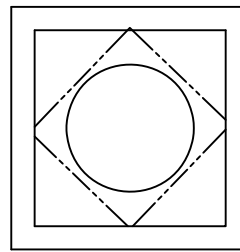
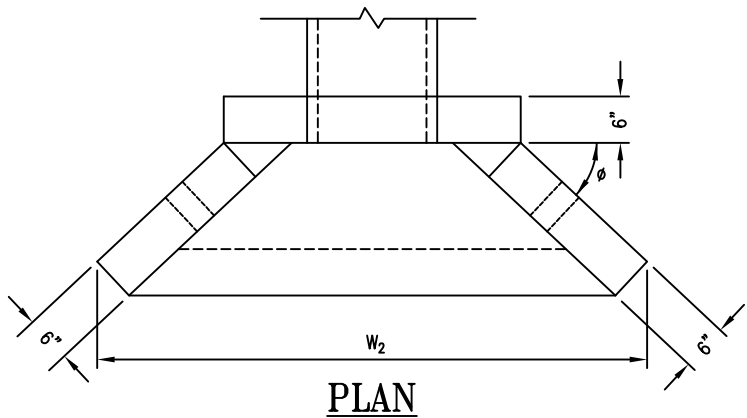

HEADWALL DIMENSIONS FOR CONCRETE PIPE											
PIPE SIZE ID.	HOLE SIZE	REINF.	W ₁	W ₂	H ₁	H ₂	H ₃	D	E	φ	WT.
12",15"	18",21"	#4	3'-2"	5'-5"	1'-3"	3'-1"	12"	1'-3"	1'-9"	40'	1600
18"	27"	#4	3'-8"	6'-1"	1'-9"	3'-7"	12"	1'-6"	2'-3"	45'	2100
21",24"	33"	#5	4'-3"	7'-2"	2'-0"	4'-3"	12"	1'-10"	2'-9"	45'	2850
27",30"	39"	#5	4'-8"	8'-4"	2'-4"	4'-9"	12"	2'-2"	3'-3"	45'	3700
36"	48"	#6	5'-8"	10'-10"	3'-3"	5'-9"	12"	2'-11"	4'-4"	45'	5600
42",48"	56",63"	#6	6'-7"	12'-6"	3'-8"	6'-8"	12"	3'-4"	5'-3"	45'	7500
54",60"	72",81"	#6	8'-9"	13'-4"	4'-5"	8'-0"	15"	3'-4"	7'-5"	50'	10000
66",72"	91"	#6	8'-9"	13'-4"	4'-5"	9'-0"	27"	3'-4"	7'-5"	50'	10000

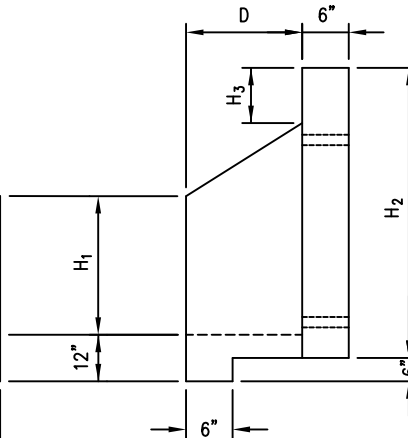
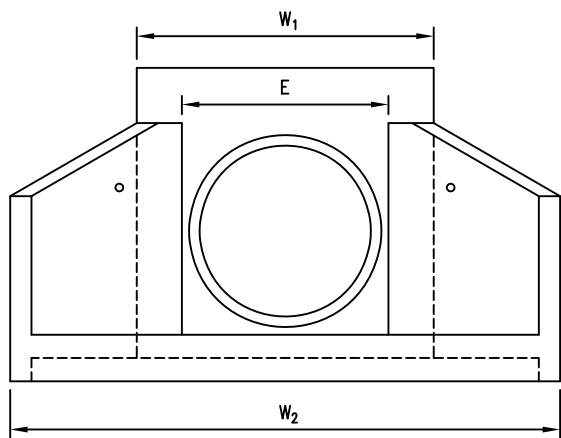

GENERAL NOTES:

1. ALL CONCRETE TO BE 4000 PSI MIN.
2. REINFORCEMENT STEEL SHALL MEET ASTM 615 GRADE 60 WITH 2" MIN. CLEARANCE.
3. CHAMFER ALL EXPOSED EDGES 3/4".
4. PRECAST HEADWALL UNIT SHALL BE CAREFULLY POSITIONED ON THE PREPARED FOUNDATION AND PIPE INSERTED INTO HEADWALL OR HEADWALL SLID OVER PIPE AND CHECKED FOR ALIGNMENT.
5. PIPE SHALL BE GROUTED INTO HEADWALL WITH CEMENTITIOUS MATERIAL BY CONTRACTOR. BONDING AGENT MAY BE USED IF REQD.
6. CARE SHALL BE TAKEN DURING BACKFILLING AND COMPACTION TO PREVENT DAMAGE AND MAINTAIN ALIGNMENT. MINOR DAMAGE TO THE UNIT MAY BE REPAIRED BY CONTRACTOR WHEN PERMITTED BY ENGINEER.
7. REINFORCEMENT VARIES WITH SIZE OF UNIT.
8. VARIOUS HOLE SIZE AND SHAPES AVAILABLE BY SPECIAL ORDER.
9. ALL DIMENSIONS ARE NOMINAL.

FRONT ELEV.

SIDE ELEV.

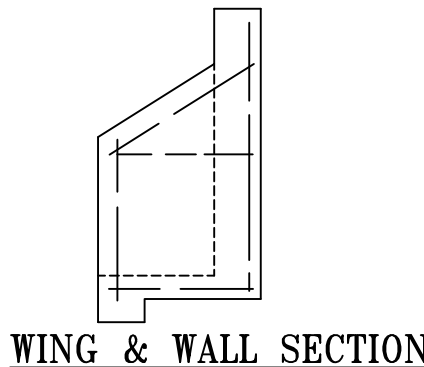
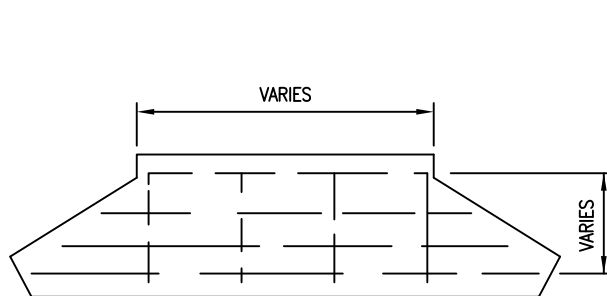

ENGINEERING DIVISION
433 HAY ST. 28301
(910) 433-1656
<http://www.fayettevillenc.gov>

PRECAST CONCRETE
HEADWALL SYSTEM
12" THRU 72" PIPE

Rev. Date: 16JAN18
Not to Scale

DR-18

SIZE D	T	L	POUNDS PER FOOT	ASTM SPEC. & CLASS	OD	A	B	C	E	F	G	J	K	M	N	PLANT
15	B2 $\frac{1}{4}$	8'	134	ASTM C76 III IV V	19 $\frac{1}{2}$	2	16 $\frac{15}{16}$	17 $\frac{1}{4}$	2	17 $\frac{3}{4}$	17	21 $\frac{3}{8}$	4 $\frac{1}{2}$	$\frac{7}{16}$	1 $\frac{1}{4}$	SR VN-KN
18	B2 $\frac{1}{2}$	8'	173	ASTM C76 III IV V	23	2	20	20 $\frac{3}{4}$	2	21 $\frac{1}{4}$	20 $\frac{1}{2}$	23 $\frac{1}{2}$	6 $\frac{1}{2}$	$\frac{3}{4}$	1 $\frac{1}{4}$	SR VN-KN
24	B3	8'	268	ASTM C76 III IV V	30	2 $\frac{1}{2}$	26 $\frac{3}{16}$	26 $\frac{7}{8}$	2 $\frac{13}{16}$	27 $\frac{3}{4}$	27	31 $\frac{1}{32}$	4 $\frac{1}{4}$	$\frac{1}{2}$	1 $\frac{1}{2}$	VN-KN SR
30	B3 $\frac{1}{2}$	8'	396	ASTM C76 III IV V	37	2 $\frac{15}{16}$	32 $\frac{1}{16}$	33 $\frac{1}{8}$	3	34 $\frac{1}{32}$	33 $\frac{1}{32}$	38 $\frac{1}{2}$	5 $\frac{1}{2}$	$\frac{3}{4}$	1 $\frac{1}{2}$	SR-K
36	B4	8'	543	ASTM C76 III IV V	44	3 $\frac{3}{4}$	39 $\frac{1}{4}$	39 $\frac{29}{32}$	3 $\frac{13}{16}$	40 $\frac{19}{32}$	40 $\frac{5}{16}$	46 $\frac{1}{2}$	6	1 $\frac{1}{4}$	2 $\frac{11}{16}$	SR-K

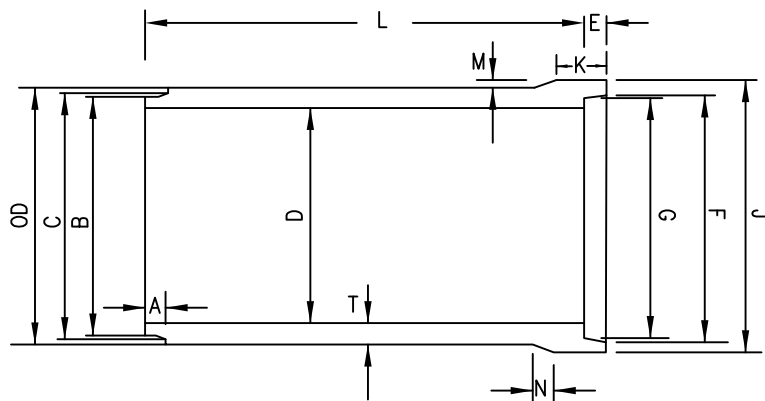

A MINIMUM OF 6" OF #57 WASHED STONE IS REQUIRED FOR ALL PIPE INSTALLATION. SEE CITY CITY OF FAYETTEVILLE STANDARD DETAIL DR-1.

MODIFIED TONGUE AND GROOVE

8 FOOT LENGTH

MORTAR OF FLEXIBLE PLASTIC TYPE JOINT

SPECIFICATIONS:
ASTM C 76-LATEST
NCDOT
REINFORCED IN ACCORDANCE WITH APPLICABLE SPECIFICATIONS

LIFT HOLES STANDARD ON 36" AS ALLOWED PER ASTM SPECIFICATIONS

MINIMUM FILL UNDER ROADWAYS	
PIPE CLASS	MINIMUM FILL
CLASS III	2'
CLASS IV	1'
CLASS V	1'

FILL HEIGHT IS MEASURED FROM THE TOP OF THE PIPE TO THE BOTTOM OF THE PAVEMENT STRUCTURE.



ENGINEERING DIVISION
433 HAY ST. 28301
(910) 433-1656
<http://www.fayettevillenc.gov>

**REINFORCED CONCRETE SEWER,
STORM DRAIN AND CULVERT
15" THRU 36" PIPE**

Rev. Date: 16JAN18
Not to Scale

DR-19

SIZE D	T	L	POUNDS PER FOOT	ASTM SPEC. & CLASS	OD	A	B	C	E	F	G	PLANT
42	C5 $\frac{1}{4}$	8'	807	ASTM C76 III IV V	52 $\frac{1}{2}$	4 $\frac{1}{4}$	45 $\frac{15}{32}$	46 $\frac{17}{32}$	4 $\frac{5}{16}$	47 $\frac{3}{16}$	46 $\frac{7}{8}$	SR
48	C5 $\frac{3}{4}$	8'	1018	ASTM C76 III IV V	59 $\frac{1}{2}$	4 $\frac{1}{4}$	51 $\frac{3}{4}$	52 $\frac{1}{2}$	4 $\frac{5}{16}$	53 $\frac{3}{16}$	52 $\frac{7}{8}$	SR
54	C6 $\frac{1}{4}$	8'	1228	ASTM C76 III IV V	66 $\frac{1}{2}$	4 $\frac{1}{4}$	57 $\frac{1}{2}$	58 $\frac{1}{4}$	4 $\frac{5}{16}$	58 $\frac{19}{32}$	58 $\frac{19}{32}$	SR
60	C6 $\frac{3}{4}$	8'	1488	ASTM C76 III IV V	73 $\frac{1}{2}$	4 $\frac{3}{4}$	63 $\frac{15}{16}$	64 $\frac{25}{32}$	4 $\frac{13}{16}$	65 $\frac{3}{32}$	65 $\frac{7}{8}$	SR
66	C7 $\frac{1}{4}$	8'/12'	1791	ASTM C76 III IV V	80 $\frac{1}{2}$	5	71	71 $\frac{11}{16}$	5 $\frac{1}{16}$	71 $\frac{7}{8}$	71 $\frac{19}{32}$	SR
72	C7 $\frac{3}{4}$	8'/12'	2052	ASTM C76 III IV V	87 $\frac{1}{2}$	5	77 $\frac{9}{32}$	77 $\frac{15}{16}$	5 $\frac{1}{16}$	78 $\frac{1}{8}$	77 $\frac{7}{8}$	SR

MINIMUM FILL UNDER ROADWAYS	
PIPE CLASS	MINIMUM FILL
CLASS III	2'
CLASS IV	1'
CLASS V	1'

FILL HEIGHT IS MEASURED FROM THE TOP OF THE PIPE TO THE BOTTOM OF THE PAVEMENT STRUCTURE.

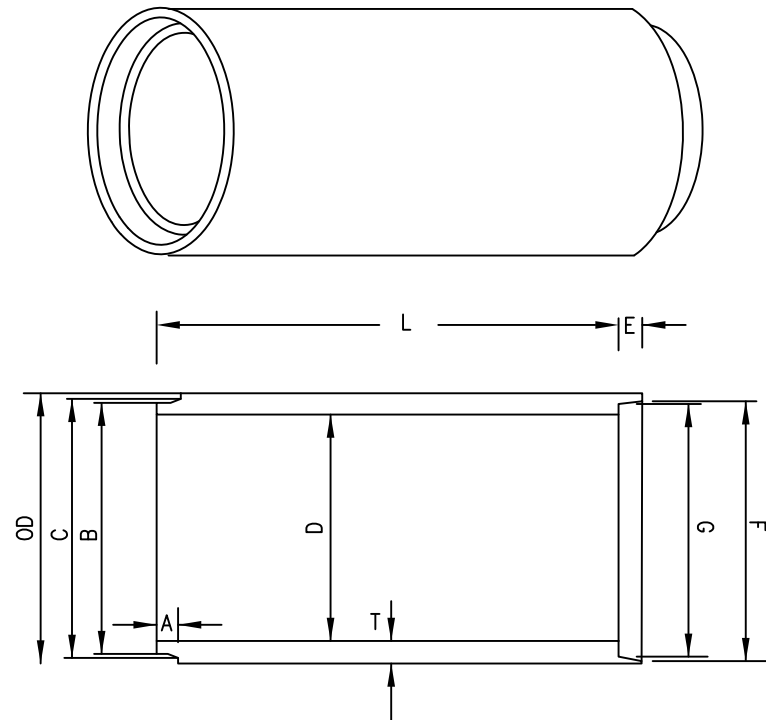

A MINIMUM OF 6" OF #57 WASHED STONE IS REQUIRED FOR ALL PIPE INSTALLATION. SEE CITY OF FAYETTEVILLE STANDARD DETAIL DR-1.

MODIFIED TONGUE AND GROOVE

8 FOOT LENGTH

MORTAR OF FLEXIBLE PLASTIC TYPE JOINT

SPECIFICATIONS:
ASTM C 76-LATEST
NCDOT
REINFORCED IN ACCORDANCE WITH APPLICABLE SPECIFICATIONS

LIFT HOLES STANDARD ON 36" AS ALLOWED PER ASTM SPECIFICATIONS



ENGINEERING DIVISION
433 HAY ST. 28301
(910) 433-1656
<http://www.fayettevillenc.gov>

**REINFORCED CONCRETE SEWER,
STORM DRAIN AND CULVERT
42" THRU 72" PIPE**

Rev. Date: 16JAN18
Not to Scale

DR-19.1

SIZE D IN.	MIN. SLOPE (FT)		CLEARANCE DIST. (FT)	
	RCP	CMP	RCP	CMP
15	0.00325	0.01107	2.4	2.3
18	0.00255	0.00868	2.7	2.6
24	0.00174	0.00592	3.3	3.1
30	0.00129	0.00439	3.8	3.6
36	0.00101	0.00345	4.3	4.1
42	0.00082	0.00281	4.9	4.6
48	0.00069	0.00235	5.4	5.1

MINIMUM FILL UNDER ROADWAYS	
PIPE CLASS	MINIMUM FILL
CLASS III	2'
CLASS IV	1'
CLASS V	1'

FILL HEIGHT IS MEASURED FROM THE TOP OF THE PIPE TO THE BOTTOM OF THE PAVEMENT STRUCTURE.

NOTES:

1. THE MAXIMUM PIPE VELOCITY SHALL NOT EXCEED 20 FT PER SEC., BUT SHALL NOT CAUSE SCOUR OR OTHER EROSION PROBLEMS IN THE RECEIVING CHANNEL.
2. SLOPES REQUIRED TO MAINTAIN MINIMUM VELOCITY OF 3 FT PER SEC. AT FULL FLOW.
3. THE MINIMUM SIZE STORM DRAIN PIPE SHALL BE 15 IN.
4. ALL STORM DRAINAGE PIPE USED WITHIN CITY RIGHT-OF-WAY SHALL BE REINFORCED CONCRETE PIPE (RCP). ALL RCP SHALL BE CLASS III OR HIGHER.
5. CLEARANCE DISTANCE IS DETERMINED FROM THE PIPE INVERT ELEVATION UP.
6. A MINIMUM OF 6" OF #57 WASHED STONE IS REQUIRED FOR ALL PIPE INSTALLATION. SEE CITY OF FAYETTEVILLE STANDARD DETAIL DR-1.



ENGINEERING DIVISION
 433 HAY ST. 28301
 (910) 433-1656
<http://www.fayettevillenc.gov>

MINIMUM SLOPE & COVER FOR
 STORM DRAIN AND CULVERT PIPE

Rev. Date: 16JAN18
 Not to Scale

DR-19.2

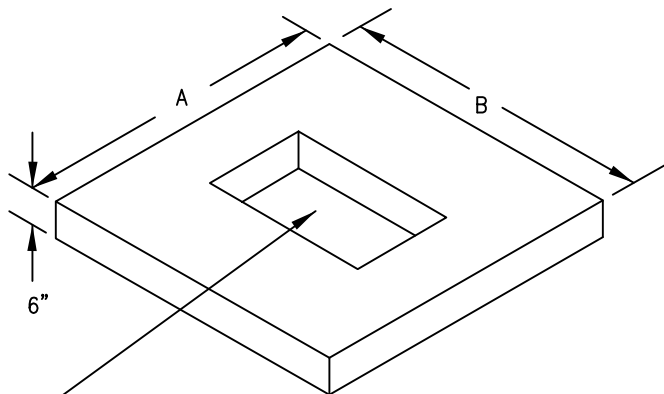

SOLID TOP AND ACCESS OPENING AS REQUIRED.

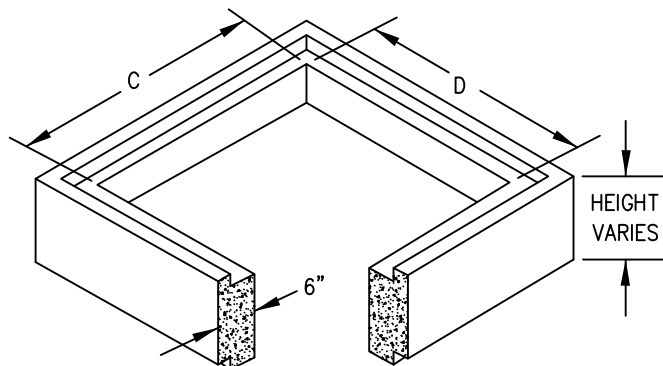

RISER HEIGHT
8"
1'-4"
2'-8"

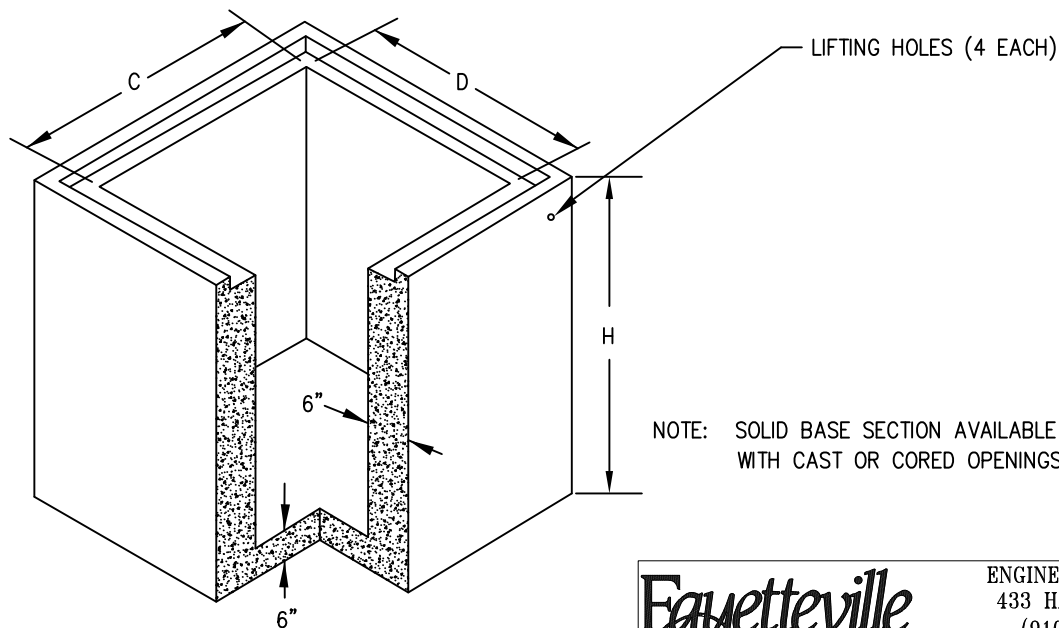

NOTE: SOLID BASE SECTION AVAILABLE WITH CAST OR CORED OPENINGS.

NOTES:

1. CONCRETE 4,000 PSI MINIMUM.
2. REINFORCING STEEL ASTM A-615 GRADE 60.
3. MEETS N.C.D.O.T. APPROVAL TO 10' DEPTH.
4. SOLID BOXES MEET H-20 LOADING TO 15' DEPTH.
5. PRECAST BOXES APPROVED FOR N.C.D.O.T. STANDARDS: 840.01, 840.02, 840.04, 840.05, 840.11, 840.12, 840.14, 840.15, 840.17, 840.18, 840.19, 840.26, 840.27, 840.28, 840.31, 840.32, AND 840.41
6. ANY MODIFICATION TO BOX MAY NULLIFY H-20 LOADING ABILITY.
7. NO WAFFLE BOXES ALLOWED IN CITY RIGHT OF WAY OR EASEMENTS.

Fayetteville
North Carolina

ENGINEERING DIVISION
433 HAY ST. 28301
(910) 433-1656
<http://www.fayettevillenc.gov>

PRECAST CONCRETE SOLID BOX
PAGE 1 OF 2

Rev. Date: 16JAN18
Not to Scale

DR-20

BOX SIZE	DIMENSIONS						BASE SECTION		
	A	B	C	D	E	F	H	MAX. PIPE DIA.	
								C WALL	D WALL
24"X24"	36"	36"	24"	24"	6"	6"	36"		
24"X44"	36"	56"	24"	44"	6"	6"	2'-6"	12"	12"
							3'-6"	18"	18"
							4'-6"	18"	30"
							5'-6"	18"	36"
26"X36"	36"	48"	26"	36"	6"	6"	2'-6"	12"	12"
							3'-6"	18"	18"
							4'-6"	18"	24"
							5'-6"	18"	24"
30"X48"	42"	60"	30"	48"	6"	6"	2'-6"	12"	12"
							3'-6"	18"	18"
							4'-6"	18"	30"
							5'-6"	18"	36"
30"X60"	42"	72"	30"	60"	6"	6"	2'-6"	12"	12"
							3'-6"	18"	18"
							4'-6"	18"	30"
							5'-6"	18"	42"
36"X36"	48"	48"	36"	36"	6"	6"	2'-6"	12"	
							3'-6"	18"	
							4'-6"	24"	
							5'-6"	24"	
48"X48"	60"	60"	48"	48"	10"	10"	2'-6"	12"	
							3'-6"	18"	
							4'-6"	30"	
							5'-6"	36"	
60"X60"	72"	72"	60"	60"	10"	10"	2'-6"	12"	
							3'-6"	18"	
							4'-6"	30"	
							5'-6"	42"	
							6'-6"	48"	

	ENGINEERING DIVISION 433 HAY ST. 28301 (910) 433-1656 http://www.fayettevillenc.gov
	<p align="center"> PRECAST CONCRETE SOLID BOX PAGE 2 OF 2 </p>
Rev. Date: 16JAN18 Not to Scale	<h1 align="center">DR-20.1</h1>

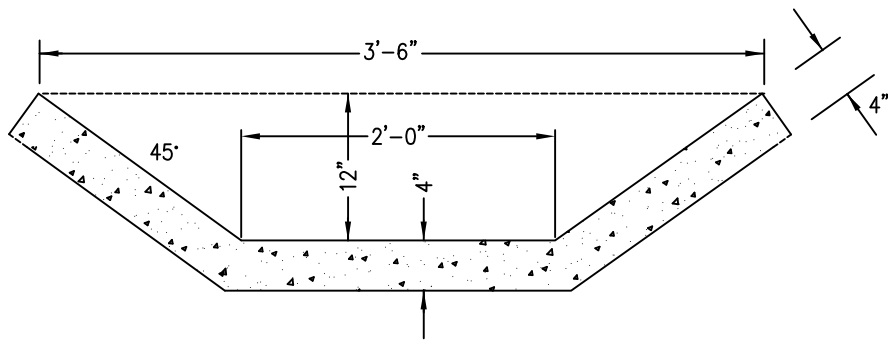

**SLOPE DRAIN, BASE DITCH
OR BERM DRAINAGE
OUTLET SWALE**

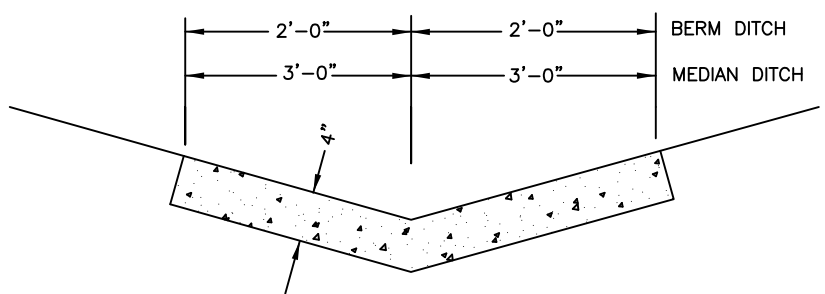

MEDIAN OR BERM SWALE

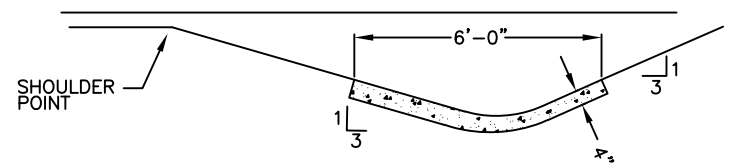

SIDE SWALE

GENERAL NOTES:

IN THE 4" CONCRETE PAVED DITCHES PLACE 1/2" EXPANSION JOINT AT 30 FT INTERVALS AND AT ALL OTHER POINTS WHERE PROPOSED SWALES ABUT RIGID OBJECTS. PLACE GROOVED JOINTS 1" DEEP AT 10' INTERVALS BETWEEN EXPANSION JOINTS.

WIDTH AND SHAPE OF PROPOSED 4" CONCRETE PAVED SWALES SHALL BE AS SHOWN OR AS DIRECTED BY THE ENGINEER.

ALL CONCRETE TO BE 3000 P.S.I. COMPRESSIVE STRENGTH.

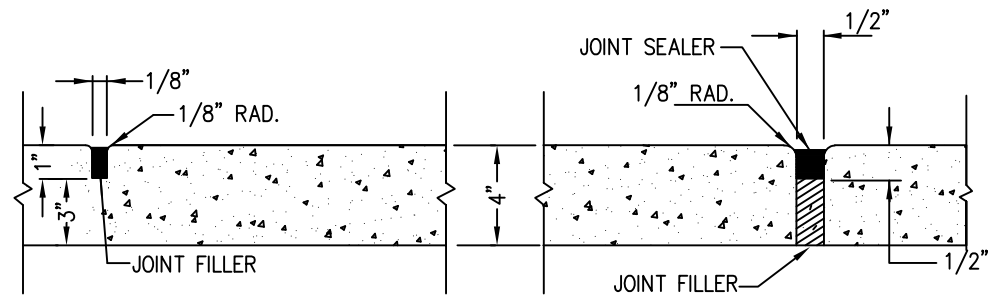

**SHOWING GROOVED
JOINT**

**SHOWING EXPANSION
JOINT**

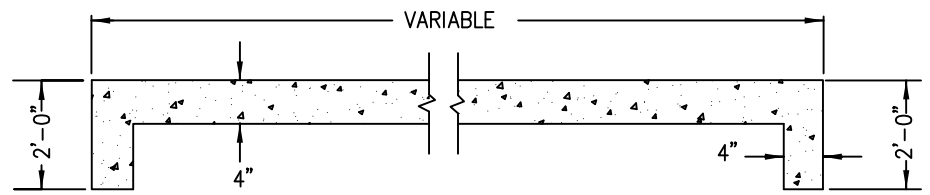

LONGITUDINAL SECTION OF PAVED SWALE

SHOWING 2'-0" CURTAIN WALL REQUIRED AT EACH END



ENGINEERING DIVISION
433 HAY ST. 28301
(910) 433-1656
<http://www.fayettevillenc.gov>

CONCRETE PAVED SWALES

Rev. Date: 16JAN18
Not to Scale

DR-21

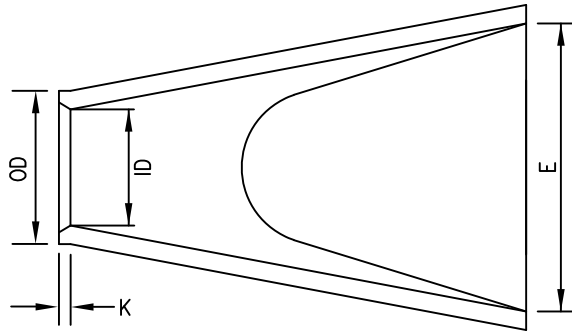

PLAN

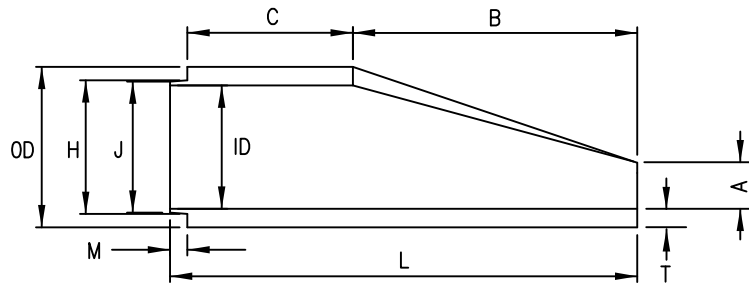

SECTION

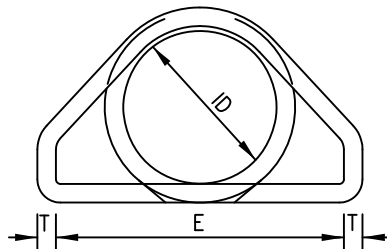

END VIEW

TABLE OF DIMENSIONS												
ID	T	OD	A	B	C	E	H	J	K	M	L	WT.
15"	2-1/4"	19-1/2"	7"	27-1/4"	47-1/2"	30"	17"	16-1/2"	2"	2"	74-3/4"	1038
18"	2-1/2"	23"	9"	27"	47-3/4"	36"	20-1/4"	19-1/2"	2"	2"	74-3/4"	1426
24"	3"	30"	9"	43"	37"	47-3/4"	26-3/4"	26-1/4"	2-13/16"	2-3/4"	80"	2137
30"	3-1/2"	37"	12"	54-1/2"	22-1/2"	60"	33-1/2"	32-1/2"	3"	2-15/16"	77"	2990
36"	4"	44"	16"	60"	37-1/2"	71"	39-3/4"	39"	3-3/4"	3-3/4"	97-1/2"	3960
42"	4-1/2"	51"	22-1/4"	61-3/8"	37"	77-1/4"	46-1/8"	45-1/8"	4-1/4"	4-1/4"	98-3/8"	5160
48"	5"	58"	25-1/4"	70-1/4"	29"	83-1/2"	52-1/2"	51-3/4"	4-1/4"	4-1/4"	99-1/4"	6480
54"	5-1/2"	65-1/4"	26"	65"	39-1/2"	89-3/4"	58-1/4"	57-1/2"	4-1/4"	4-1/4"	104-1/2"	9370
60"	6"	72-1/4"	28-1/2"	57-1/2"	46"	96"	64-3/4"	64"	4-3/4"	4-3/4"	103-1/2"	11650

GENERAL NOTES:

1. REFER TO NCDOT STANDARD SPECIFICATIONS AND DRAWINGS FOR MATERIALS AND INSTALLATION.
2. CONCRETE SHALL BE MINIMUM 3500 P.S.I.



ENGINEERING DIVISION
 433 HAY ST. 28301
 (910) 433-1656
<http://www.fayettevillenc.gov>

**REINFORCED PRECAST CONCRETE
 FLARED END SECTIONS**

Rev. Date: 16JAN18
 Not to Scale

DR-23

**TO FLAT AREA -
NO WELL DEFINED CHANNEL**

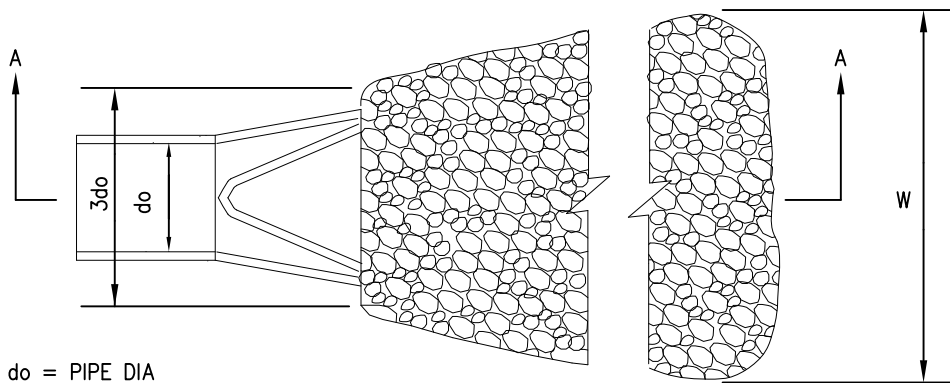

do = PIPE DIA
 La = APRON LENGTH
 W = APRON WIDTH
 3 X PIPE Ø MIN
 d = APRON DEPTH

PLAN

WELL DEFINED CHANNEL

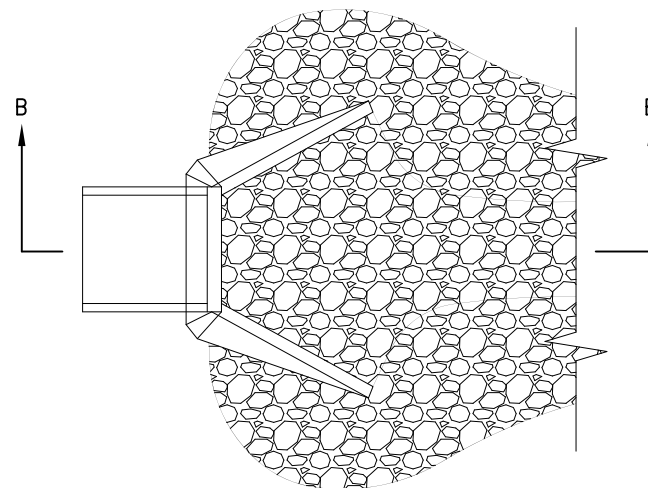

PLAN

1. La is the length of the riprap apron.
2. d = 1.5 times the maximum stone diameter but not less than 6"
3. A filter blanket or filter fabric should be installed between the riprap and soil foundation.
4. In a well-defined channel, extend the apron up the channel banks to an elevation of 6" above the maximum tailwater depth or to the top of the bank, whichever is less.

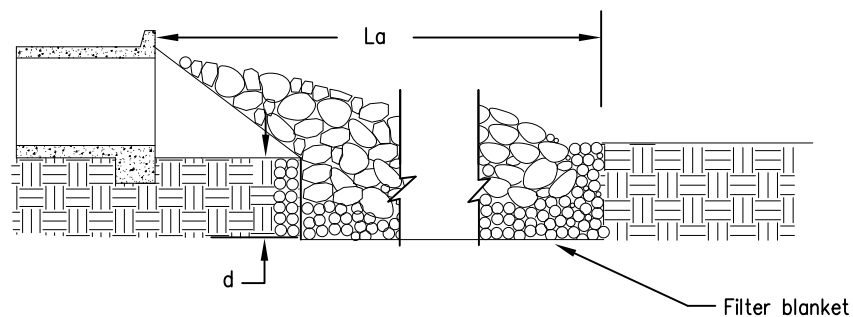

SECTION B-B

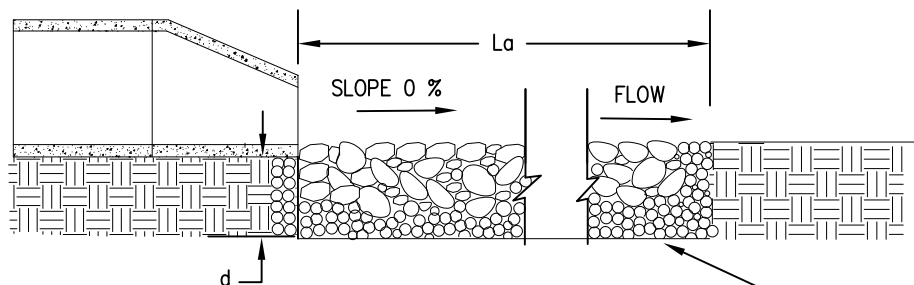

SECTION A-A

Fayetteville
North Carolina

ENGINEERING DIVISION
 433 HAY ST. 28301
 (910) 433-1656
<http://www.fayettevillenc.gov>

PIPE OUTLET

Rev. Date: 16JAN18
 Not to Scale

DR-24

NOTES:

SEE NCESCPDM PAGE 8.06.3 & 8.06.4 FOR DIMENSIONS

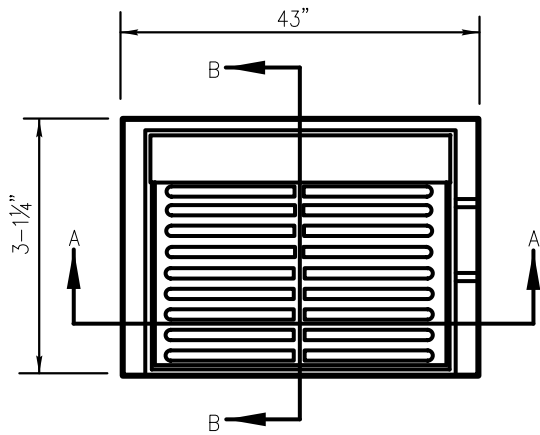

PLAN

FRAME, GRATE, & HOOD ASS'Y

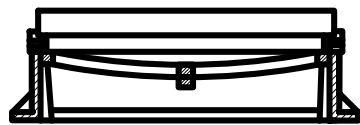

SECTION - AA

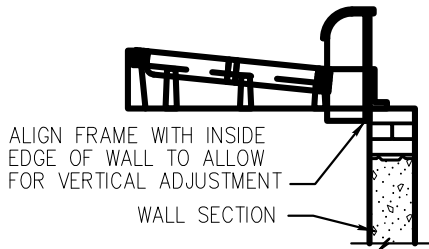

SECTION - BB

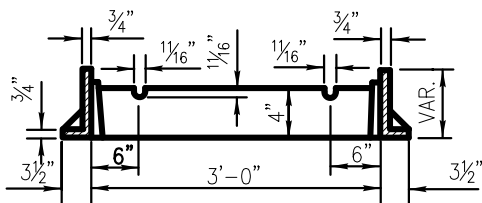

SECTION - KK

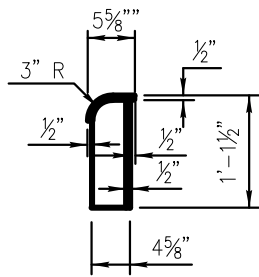

SECTION - RR

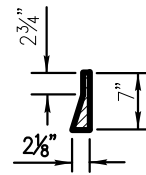

SECTION - LL

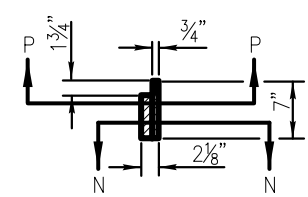

SECTION - MM

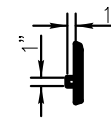

SECTION - PP

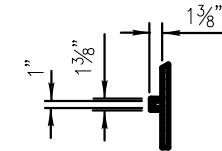

SECTION - NN

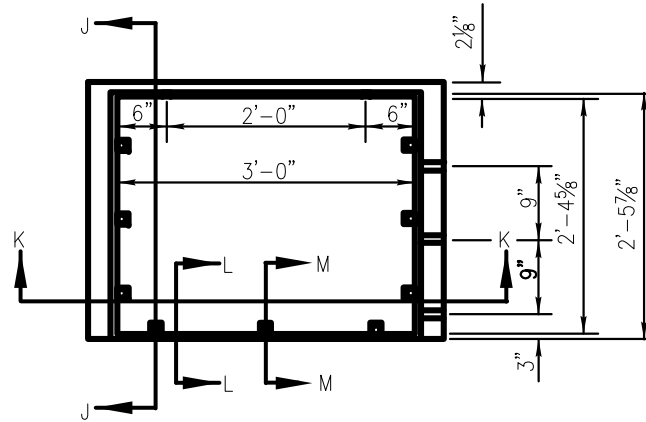

FRAME PLAN

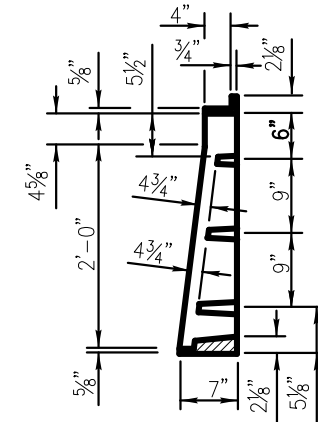

SECTION - JJ

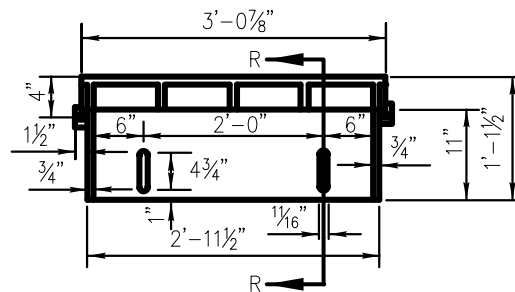

HOOD ELEVATION

NOTE: USE TYPE "E", "F" AND "G" GRATE
UNLESS OTHERWISE NOTED.

Fayetteville
North Carolina

ENGINEERING DIVISION
433 HAY ST. 28301
(910) 433-1656
<http://www.fayettevillenc.gov>

**STANDARD FRAME, GRATES AND HOOD
FOR USE ON STANDARD CATCH BASIN
ADOPTED FROM NCDOT
STANDARD NO. 840.03 (PAGE 1 OF 2)**

Rev. Date: 16JAN18
Not to Scale

DR-26

DETAIL SHOWING TYPES OF GRATES
USE ACCORDING TO WATER FLOW.

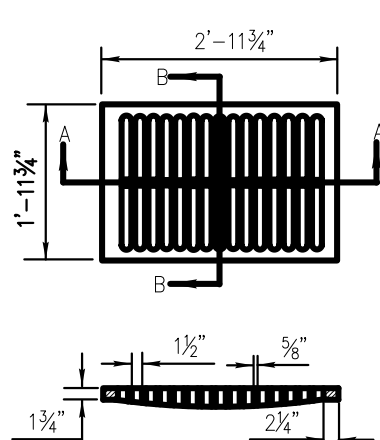
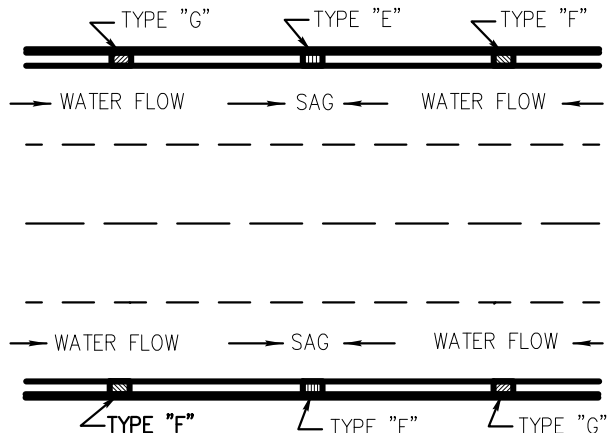

SECTION A-A

SECTION B-B

TYPE - E

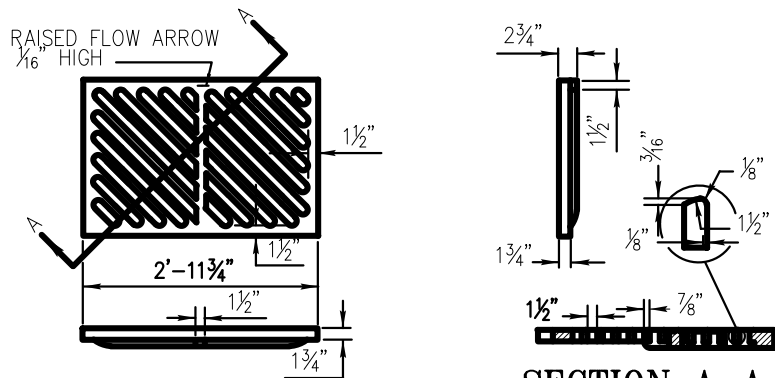

SECTION A-A

TYPE - F

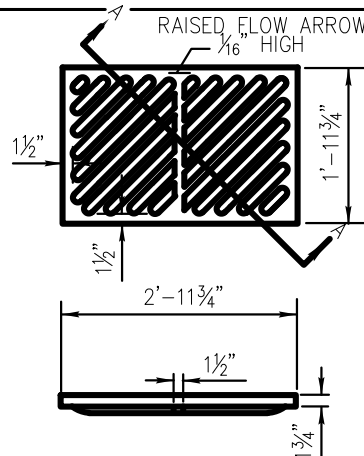

TYPE G

SECTION A-A

Fayetteville
North Carolina

ENGINEERING DIVISION
433 HAY ST. 28301
(910) 433-1656
<http://www.fayettevillenc.gov>

STANDARD FRAME, GRATES AND HOOD
FOR USE ON STANDARD CATCH BASIN
ADOPTED FROM NCDOT
STANDARD NO. 840.03 (PAGE 2 OF 2)

Rev. Date: 16JAN18
Not to Scale

DR-26.1

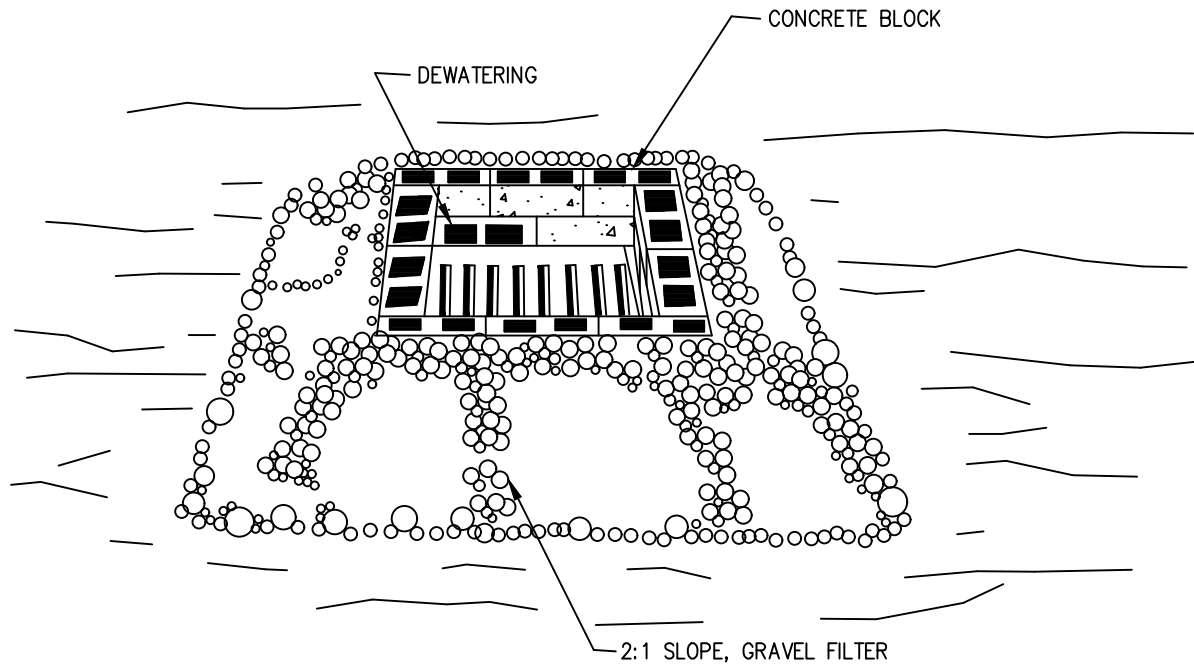

CONSTRUCTION SPECIFICATIONS

1. LAY ONE BLOCK ON EACH SIDE OF THE STRUCTURE ON ITS SIDE ON THE BOTTOM ROW TO ALLOW POOL DRAINAGE. THE FOUNDATION SHOULD BE EXCAVATED AT LEAST 2 INCH BELOW THE CREST OF THE STORM DRAIN. PLACE THE BOTTOM ROW OF THE BLOCK AGAINST THE EDGE OF THE STORM DRAIN FOR LATERAL SUPPORT AND TO AVOID WASHOUTS WHEN OVERFLOW OCCURS. IF NEEDED, GIVE LATERAL SUPPORT TO SUBSEQUENT ROWS BY PLACING 2x4 WOOD STUDS THROUGH BLOCK OPENINGS.
2. CAREFULLY FIT HARDWARE CLOTH OR COMPARABLE WIRE MESH WITH 1/2-INCH OPENING OVER ALL BLOCK OPENING TO HOLD GRAVEL IN PLACE.
3. USE CLEAN GRAVEL, 3/4- TO 1/2-INCH IN DIAMETER, PLACED 2 INCHES BELOW THE TOP OF THE BLOCK ON A 2:1 SLOPE OR FLATTER AND SMOOTH IT TO AN EVEN GRADE. DOT #57 WASHED STONE IS RECOMMENDED.

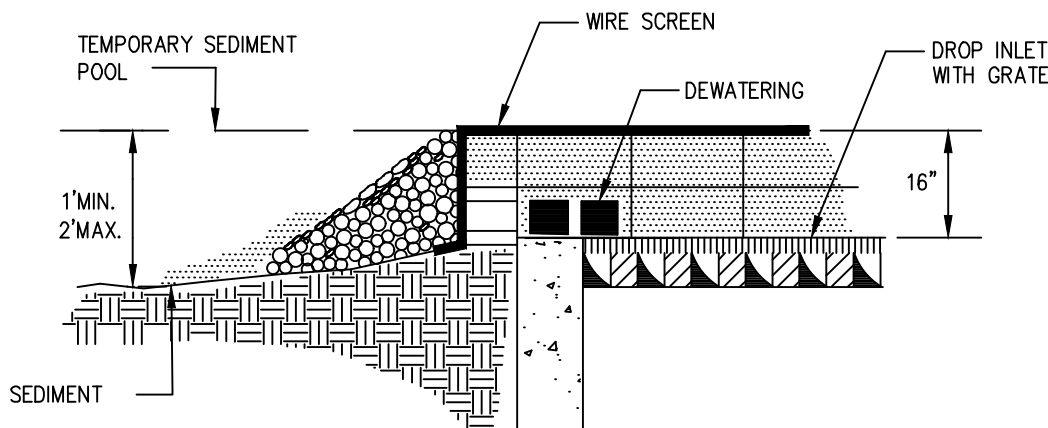

Fayetteville
North Carolina

ENGINEERING DIVISION
433 HAY ST. 28301
(910) 433-1656
<http://www.fayettevillenc.gov>

TYPICAL BLOCK AND GRAVEL DROP INLET PROTECTION

Rev. Date: 16JAN18
Not to Scale

EC-1

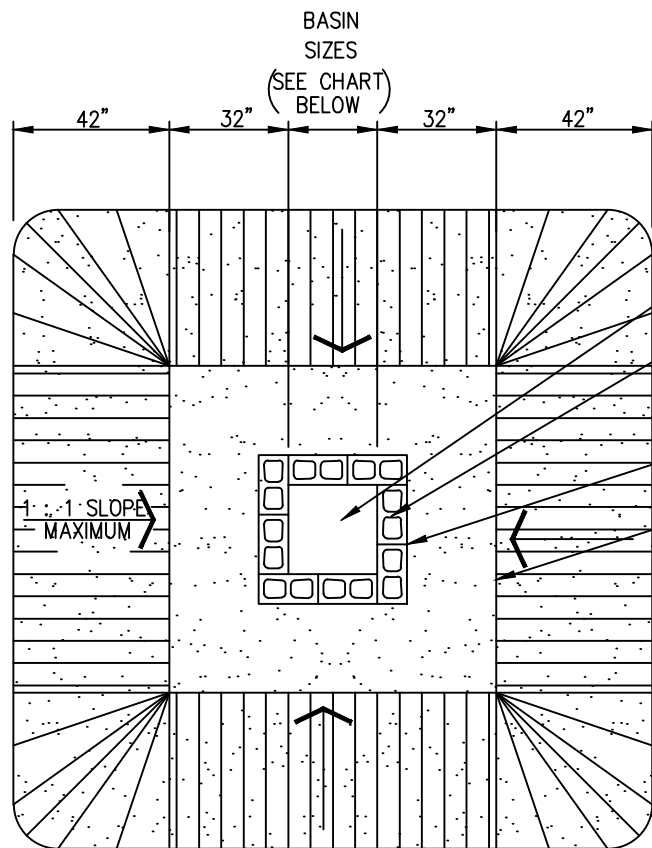
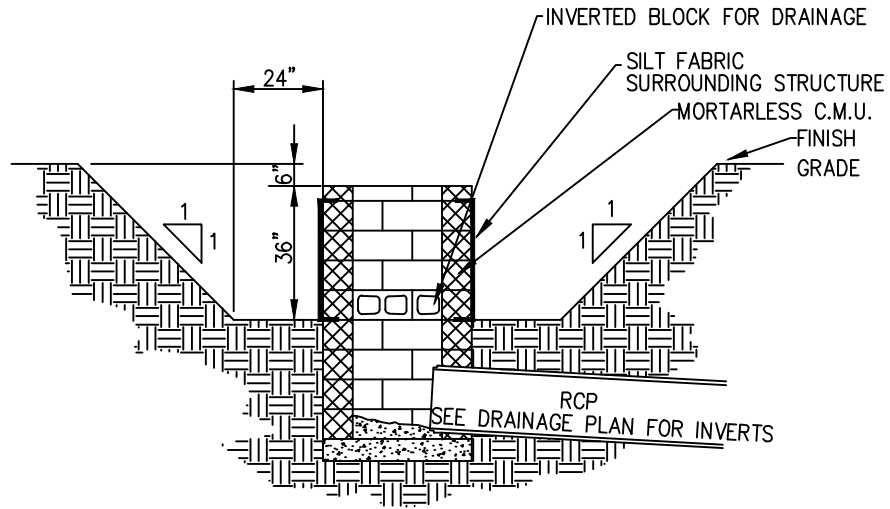

- INVERT OF DRAINAGE STRUCTURE (ELEV. SEE PLAN)
- 8" MORTARLESS C.M.U.
- TOP OF STORAGE AREA (ELEV. 3.5')
- TOP OF WALL (ELEV. 3.0')
- BOTTOM OF STORAGE AREA (ELEV. 0.0')

STRUCTURES	
SIZE	STORAGE CAPACITY
2 X 2	326 CF
2 X 3	342 CF
2 X 6	474 CF
3 X 3	425 CF
3 X 4	449 CF

Fayetteville
North Carolina

ENGINEERING DIVISION
433 HAY ST. 28301
(910) 433-1656
<http://www.fayettevillenc.gov>

TYPICAL BLOCK DROP INLET PROTECTION

Rev. Date: 16JAN18
Not to Scale

EC-1.1

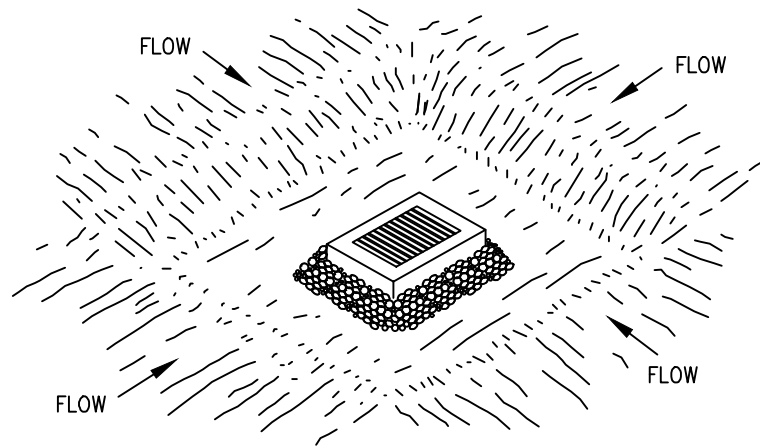

GENERAL NOTES

1. CLEAR THE AREA OF ALL DEBRIS THAT MIGHT HINDER EXCAVATION AND DISPOSAL OF SPOIL.
2. GRADE THE APPROACH OF THE INLET UNIFORMLY.
3. PROTECT WEEP HOLES BY GRAVEL.
3. WHEN THE CONTRIBUTING DRAINAGE AREA HAS BEEN PERMANENTLY STABILIZED, SEAL WEEP HOLES, FILL THE EXCAVATED BASIN WITH STABLE SOIL TO FINAL GRADING ELEVATIONS, COMPACT THE FILL PROPERLY AND STABILIZE.

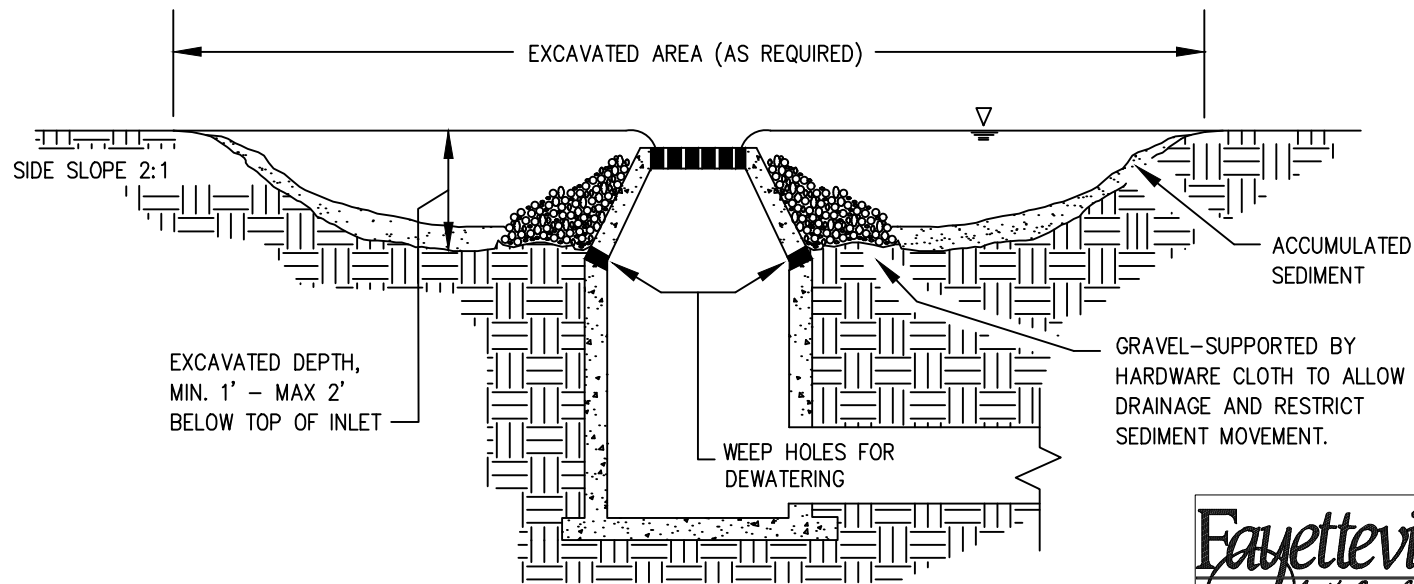

Fayetteville
North Carolina

ENGINEERING DIVISION
433 HAY ST. 28301
(910) 433-1656
<http://www.fayettevillenc.gov>

TYPICAL EXCAVATED
DROP INLET PROTECTION

Rev. Date: 16JAN18
Not to Scale

EC-1.2

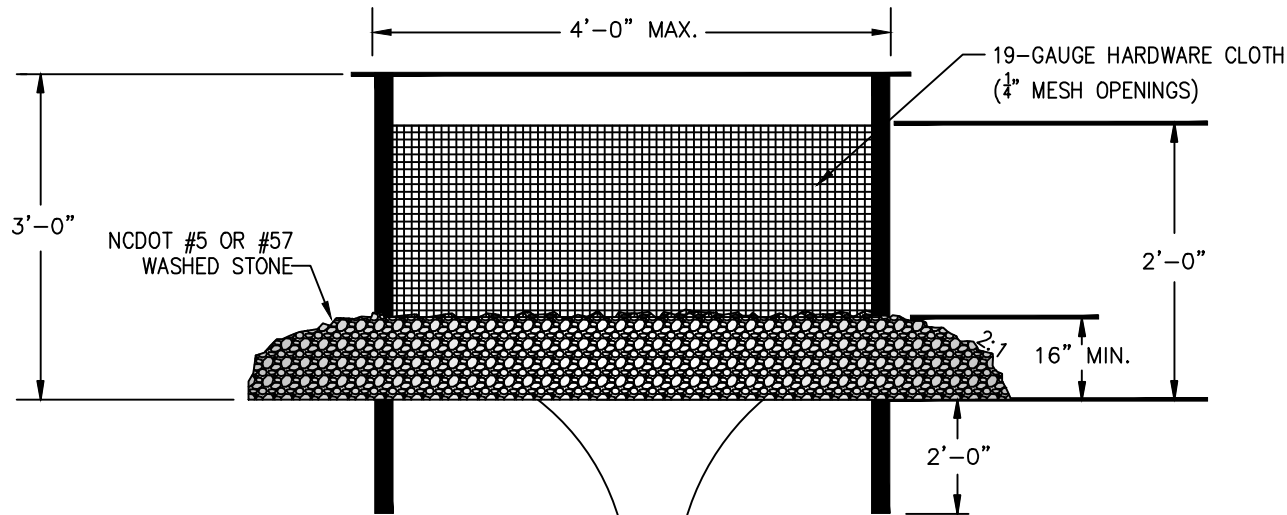

GENERAL NOTES:

1. UNIFORMLY GRADE A SHALLOW DEPRESSION APPROACHING THE INLET.
2. DRIVE 5-FOOT STEEL POSTS 2 FEET INTO THE GROUND SURROUNDING THE INLET. SPACE POSTS EVENLY AROUND THE PERIMETER OF THE INLET, A MAXIMUM OF 4 FEET APART.
3. SURROUND THE POSTS WITH WIRE MESH HARDWARE CLOTH. SECURE THE WIRE MESH TO THE STEEL POSTS AT THE TOP, MIDDLE, AND BOTTOM. PLACING A 2-FOOT FLAP OF THE WIRE MESH UNDER THE GRAVEL FOR ANCHORING IS RECOMMENDED.
4. PLACE CLEAN GRAVEL (NC DOT #5 OR #57 STONE) ON A 2:1 SLOPE WITH A HEIGHT OF 16 INCHES AROUND THE WIRE, AND SMOOTH TO AN EVEN GRADE.
5. ONCE THE CONTRIBUTING DRAINAGE AREA HAS BEEN STABILIZED, REMOVE ACCUMULATED SEDIMENT, AND ESTABLISH FINAL GRADING ELEVATIONS.
6. COMPACT THE AREA PROPERLY AND STABILIZED IT WITH GROUND COVER.

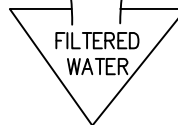

NCDOT #5 OR #57
WASHED STONE

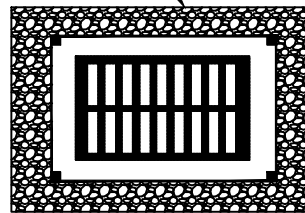

Fayetteville
North Carolina

ENGINEERING DIVISION
433 HAY ST. 28301
(910) 433-1656
<http://www.fayettevillenc.gov>

**TYPICAL HARDWARE CLOTH
AND GRAVEL DROP INLET
PROTECTION**

Rev. Date: 16JAN18
Not to Scale

EC-1.3

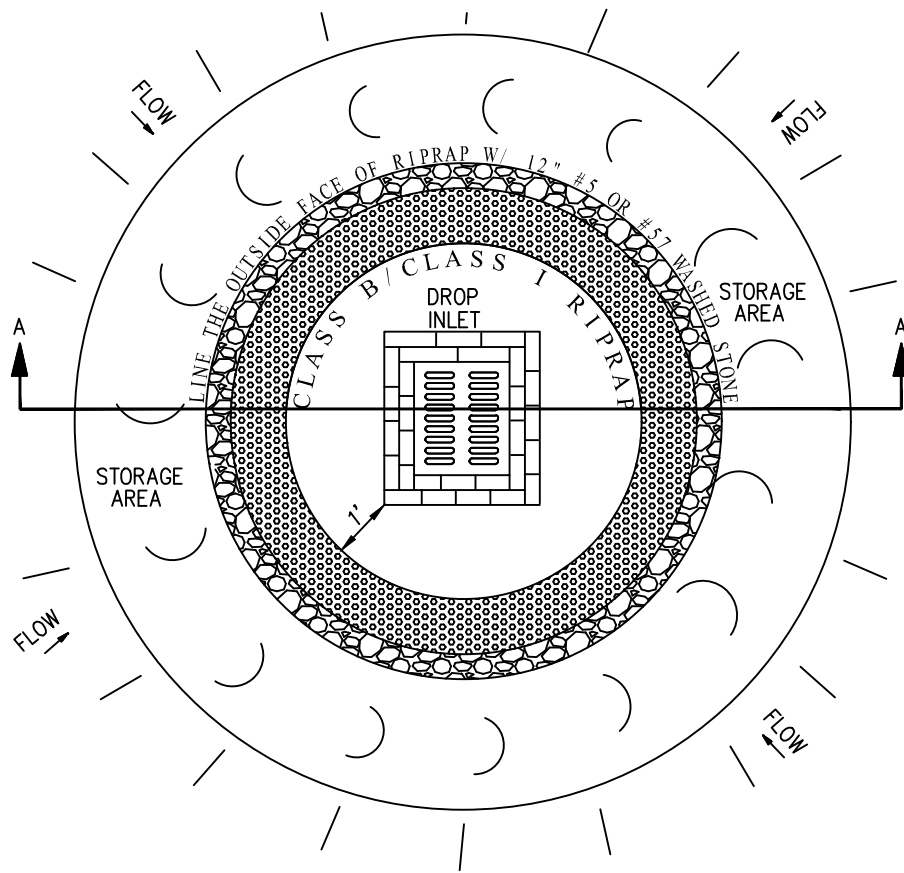

PLAN VIEW

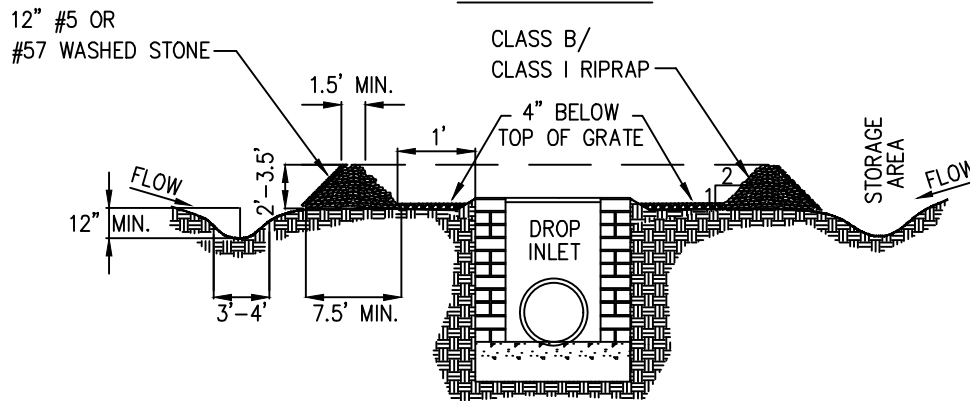

SECTION A-A

GENERAL NOTES:

1. SEDIMENT SHALL BE REMOVED AND TRAP RESTORED TO ITS ORIGINAL DIMENSIONS WHEN THE SEDIMENT HAS ACCUMULATED TO 1/2 THE DESIGN DEPTH OF THE TRAP.
2. REMOVED SEDIMENT SHALL BE DEPOSITED IN A SUITABLE AREA AND IN SUCH A MANNER THAT IT WILL NOT ERODE.
3. THE STRUCTURE SHALL BE INSPECTED BY THE FINANCIALLY RESPONSIBLE PARTY OR HIS AGENT AFTER EACH STORM EVENT AND REPAIRS MADE AS NECESSARY.
4. CONSTRUCTION OPERATIONS SHALL BE CARRIED OUT IN SUCH A MANNER THAT EROSION AND WATER POLLUTION ARE MINIMIZED.
5. THE SEDIMENT TRAP SHALL BE REMOVED AND THE AREA STABILIZED WHEN THE DRAINAGE BASIN HAS BEEN PROPERLY STABILIZED.
6. ON LARGER DRAINAGE AREAS RIP RAP MAY BE REQUIRED UNDER THE WASHED STONE.

NOTE:

SEE SECTION 6.54 OF THE NC EROSION CONTROL MANUAL FOR ADDITIONAL INFORMATION.



ENGINEERING DIVISION
 433 HAY ST. 28301
 (910) 433-1656
<http://www.fayettevillenc.gov>

**TEMPORARY ROCK DOUGHNUT
 INLET PROTECTION**

Rev. Date: 16JAN18
 Not to Scale

EC-1.4

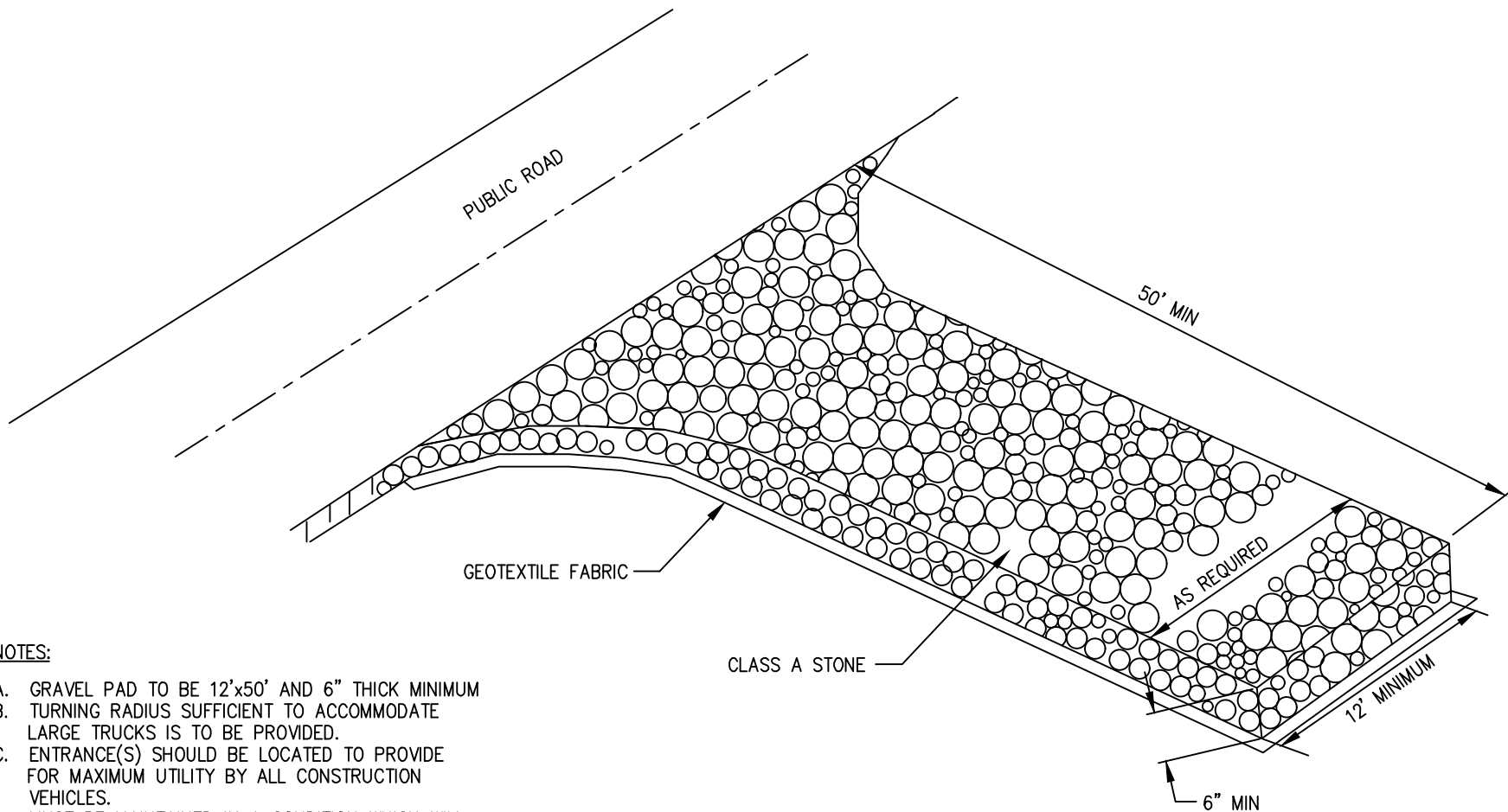

NOTES:

- A. GRAVEL PAD TO BE 12'x50' AND 6" THICK MINIMUM
- B. TURNING RADIUS SUFFICIENT TO ACCOMMODATE LARGE TRUCKS IS TO BE PROVIDED.
- C. ENTRANCE(S) SHOULD BE LOCATED TO PROVIDE FOR MAXIMUM UTILITY BY ALL CONSTRUCTION VEHICLES.
- D. MUST BE MAINTAINED IN A CONDITION WHICH WILL PREVENT TRACKING OR DIRECT FLOW OF MUD ONTO STREETS. PERIODIC TOPDRESSING WITH STONE WILL BE NECESSARY; KEEP SOME HANDY.
- E. ANY MATERIAL WHICH STILL MAKES IT ONTO THE ROAD MUST BE CLEANED UP IMMEDIATELY.
- F. GEOTEXTILE FABRICS SHALL BE USED BENEATH STONE TO IMPROVE STABILITY OF THE FOUNDATION.
- G. APPLICABLE AT ALL POINTS OF INGRESS & EGRESS UNTIL SITE IS STABILIZED. FREQUENT CHECKS OF THE DEVICE AND TIMELY MAINTTENANCE MUST BE PROVIDED.

Fayetteville
North Carolina

ENGINEERING DIVISION
 433 HAY ST. 28301
 (910) 433-1656
<http://www.fayettevillenc.gov>

**GRAVEL CONSTRUCTION
 ENTRANCE/EXIT**

Rev. Date: 16JAN18
 Not to Scale

EC-2

TEMPORARY SEDIMENT TRAP DESIGN CRITERIA	
DRAINAGE AREA (ACRES)	< 1 AC.
MIN. LENGTH TO WIDTH RATIO	2:1
MIN. SEDIMENT STORAGE VOLUME REQUIRED	3600 (CU. FT. PER AC. DISTURBED)
SURFACE AREA REQUIRED	435 (SQ. FT. PER CFS Q10)
POROUS BAFFLES REQUIRED	3
SPILLWAY WEIR LENGTH	4.0 FT MINIMUM

NOTE:

PLEASE REFER TO NCSCPD M SECTION #6.60 FOR ADDITIONAL DESIGN AND CONSTRUCTION SPECIFICATIONS REGARDING TEMPORARY SEDIMENT TRAPS.

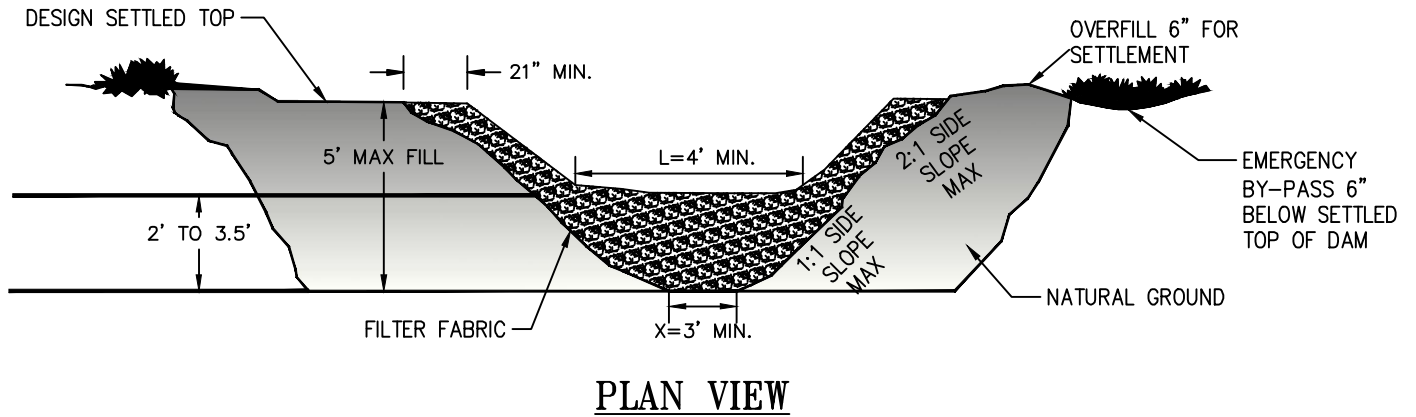
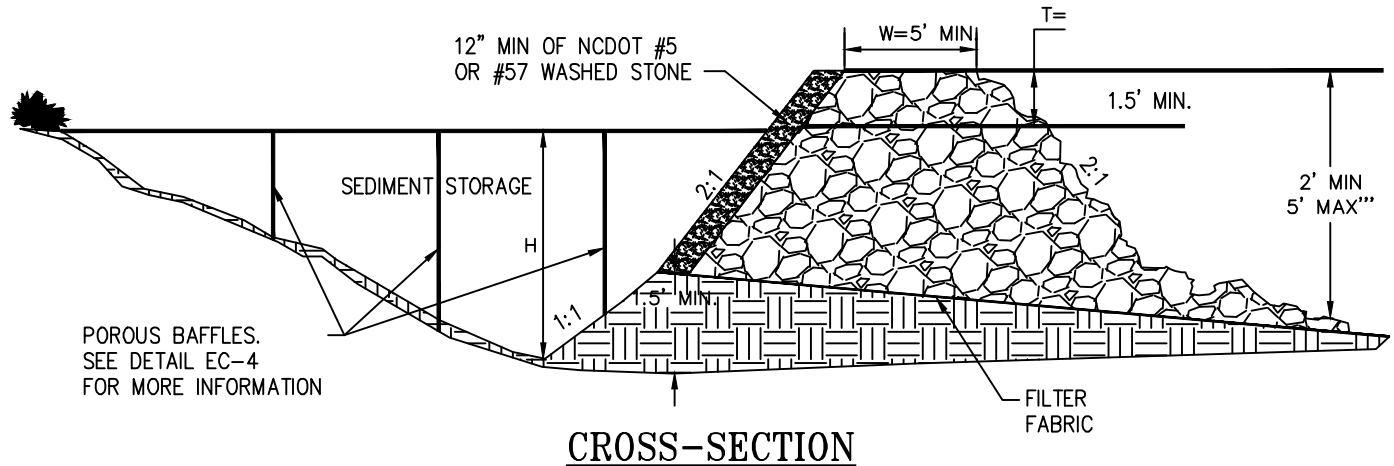

MAINTENANCE

INSPECT TEMPORARY SEDIMENT TRAPS AT LEAST WEEKLY AND AFTER EACH PERIOD OF SIGNIFICANT RAINFALL (1/2" OR GREATER). REMOVE SEDIMENT AND RESTORE TRAP TO ITS ORIGINAL DIMENSIONS WHEN THE SEDIMENT HAS ACCUMULATED TO ONE-HALF THE DESIGN DEPTH OF THE TRAP. PLACE THE SEDIMENT THAT IS REMOVED IN A DESIGNATED DISPOSAL AREA AND REPLACE THE PART OF GRAVEL FACING THAT IS IMPAIRED BY SEDIMENT.

CHECK THE STRUCTURE FOR DAMAGE FROM EROSION OF PIPING. PERIODICALLY CHECK THE DEPTH OF THE SPILLWAY TO ENSURE IT IS A MINIMUM OF 1.5 FT. BELOW THE LOW POINT OF THE EMBANKMENT. IMMEDIATELY FILL ANY SETTLEMENT OF THE EMBANKMENT TO SLIGHTLY ABOVE DESIGN GRADE. ANY RIP RAP DISPLACED FROM THE SPILLWAY MUST BE REPLACED IMMEDIATELY.

AFTER ALL SEDIMENT-PRODUCING AREAS HAVE BEEN PERMANENTLY STABILIZED, REMOVE THE STRUCTURE AND ALL UNSTABLE SEDIMENT. SMOOTH THE AREA TO BLEND WITH THE ADJOINING AREAS AND STABILIZE PROPERLY.



ENGINEERING DIVISION
433 HAY ST. 28301
(910) 433-1656
<http://www.fayettevillenc.gov>

**TEMPORARY
SEDIMENT TRAP**

Rev. Date: 16JAN18
Not to Scale

EC-3

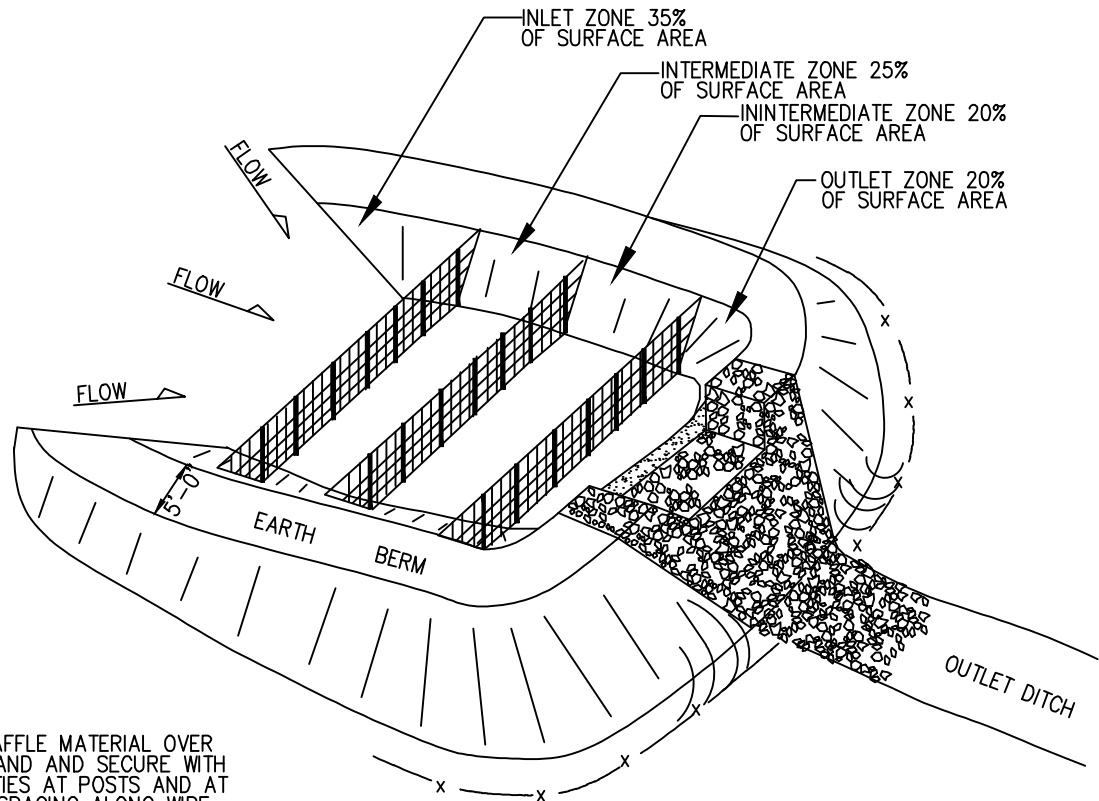

GENERAL NOTES:

1. DRIVE 5' STEEL POST AT LEAST 24" INTO SOLID GROUND.
2. USE 12" 11 GA STAPLES 1' APART HORIZONTALLY AND VERTICALLY TO ATTACH THE FILTER FABRIC TO THE WIRE FENCE.
3. MINIMUM BAFFLE SPACING IS 10'.
4. THE FLOOR OF THE BASIN IN THE OUTLET ZONE AND BERMS SHOULD BE SEEDED IMMEDIATELY AFTER THE BASIN IS CONSTRUCTED.
5. REFER TO NCESCPDM SECTION #6.65 FOR ADDITIONAL SPECIFICATIONS.

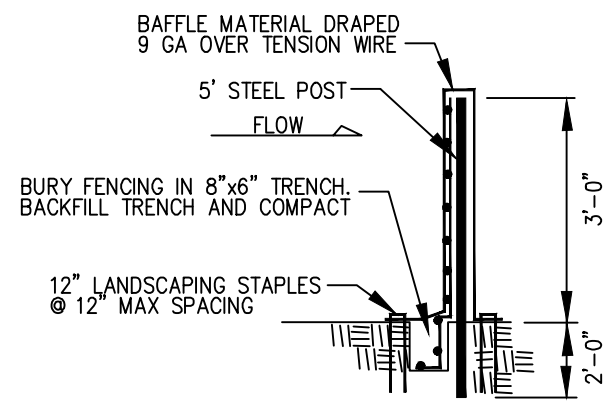
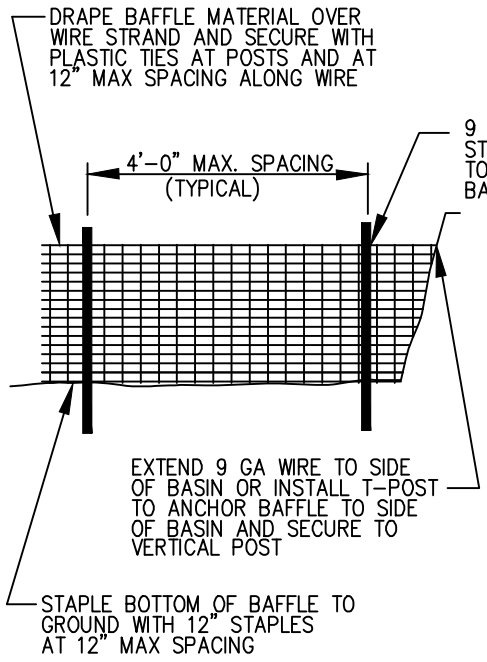

ENGINEERING DIVISION
 433 HAY ST. 28301
 (910) 433-1656
<http://www.fayettevillenc.gov>

**BAFFLE
 INSTALLATION**

Rev. Date: 16JAN18
 Not to Scale

EC-4

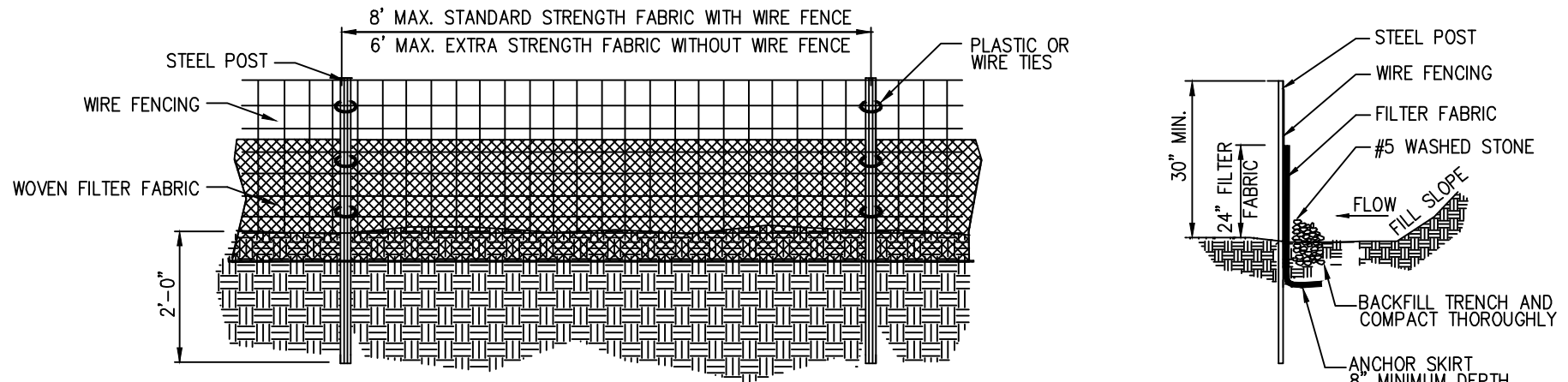

GENERAL NOTES:

1. FILTER FABRIC FENCE SHALL BE A MINIMUM OF 32" IN WIDTH AND SHALL HAVE A MINIMUM OF 6 LINE WIRES WITH 12" STAY SPACING.
2. WOVEN FILTER FABRIC BE USED WHERE SILT FENCE IS TO REMAIN FOR A PERIOD OF MORE THAN 30 DAYS.
3. STEEL POSTS SHALL BE 5'-0" IN HEIGHT AND BE OF THE SELF-FASTENER ANGLE STEEL TYPE.
4. WIRE FENCING SHALL BE AT LEAST #10 GAGE WITH A MINIMUM OF 6 LINE WIRES WITH 12" STAY SPACING.
5. TURN SILT FENCE UP SLOPE AT ENDS.
6. WIRE MESH SHALL BE MIN. 13 GAGE WITH MAXIMUM 12" OPENINGS.
7. WIRE AND WASHED STONE IS REQUIRED TO BE SHOWN ON PLANS AT THE TOE OF SLOPES GREATER THAN 10 FEET VERTICAL (2:1 SLOPE)
8. ORANGE SAFETY FENCE IS REQUIRED AT BACK OF SILT FENCE WHEN GRADING IS ADJACENT TO SWM BUFFERS, STREAMS OR WETLANDS THE COLOR ORANGE IS RESERVED FOR VISUAL IDENTIFICATION OF ENVIRONMENTALLY SENSITIVE AREAS.
9. DRAINAGE AREA CAN NOT BE GREATER THAN 1/4 ACRE PER 100 FT OF FENCE.
10. SLOPE LENGTHS CAN NOT EXCEED CRITERIA SHOWN IN TABLE 6.62A NORTH CAROLINA EROSION AND SEDIMENT CONTROL PLANNING AND DESIGN MANUAL.
11. DO NOT INSTALL SEDIMENT FENCE ACROSS STREAMS, DITCHES, WATERWAYS OR OTHER AREAS OF CONCENTRATED FLOW.

MAINTENANCE NOTES:

1. FILTER BARRIERS SHALL BE INSPECTED BY THE FINANCIALLY RESPONSIBLE PARTY OR HIS AGENT IMMEDIATELY AFTER EACH RAINFALL AND AT LEAST DAILY DURING PROLONGED RAINFALL. ANY REPAIRS NEEDED SHALL BE MADE IMMEDIATELY.
2. SHOULD THE FABRIC DECOMPOSE OR BECOME INEFFECTIVE PRIOR TO THE END OF THE EXPECTED USABLE LIFE AND THE BARRIER STILL IS NECESSARY, THE FABRIC SHALL BE REPLACED PROMPTLY.
3. SEDIMENT DEPOSITS SHOULD BE REMOVED WHEN DEPOSITS REACH HALF THE HEIGHT OF THE BARRIER. ANY SEDIMENT DEPOSITS REMAINING IN PLACE AFTER THE SILT FENCE IS REMOVED SHALL BE DRESSED TO CONFORM TO THE EXISTING GRADE, PREPARED AND SEEDED.



ENGINEERING DIVISION
 433 HAY ST. 28301
 (910) 433-1656
<http://www.fayettevillenc.gov>

**HIGH HAZARD
 TEMPORARY SILT FENCE**

**Rev. Date: 16JAN18
 Not to Scale**

EC-5

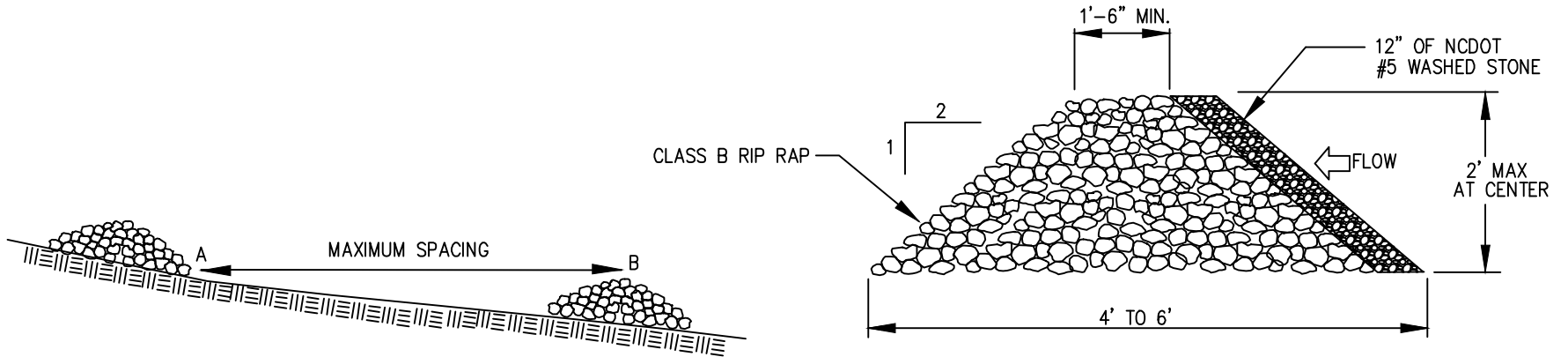

A AND B ARE AT EQUAL ELEVATIONS

CROSS SECTION

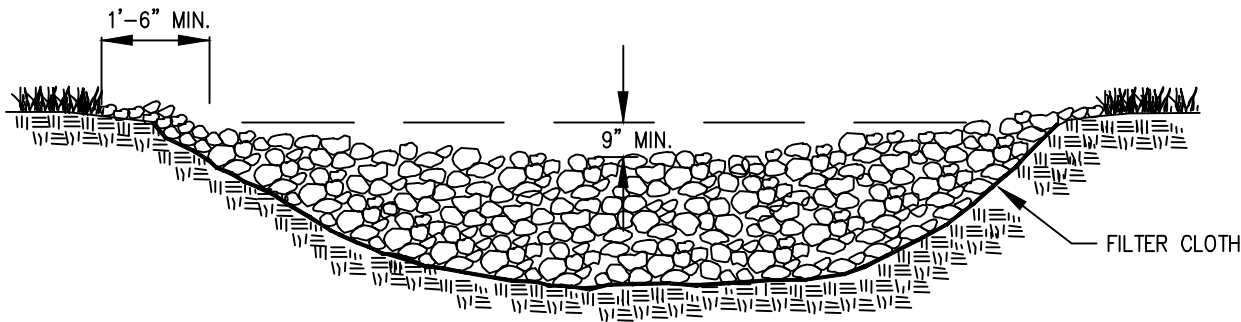

PLAN

GENERAL NOTES:

1. RIPRAP SIZE TO BE CLASS B RIPRAP
2. CHECK DAMS MAY BE USED IN SLOPING DITCHES OR CHANNELS TO SLOW VELOCITY OR TO CREATE SEDIMENT TRAPS.
3. ENSURE THAT MAXIMUM SPACING BETWEEN DAMS PLACES THE TOE OF THE UPSTREAM DAM AT THE SAME ELEVATION AS THE DOWNSTREAM DAM (SEE DIAGRAM BELOW).
4. REFER TO NCESCPDM SECTION #6.83 FOR ADDITIONAL SPECIFICATIONS.



ENGINEERING DIVISION
 433 HAY ST. 28301
 (910) 433-1656
<http://www.fayettevillenc.gov>

TEMPORARY ROCK
 CHECK DAM

Rev. Date: 16JAN18
 Not to Scale

EC-6

WARMER SEASON

COOL SEASON

SEEDING MIXTURE	100 lbs/acre of tall fesue 25 lbs/acre of german millet 25 lbs/acre of hulled bermuda	100 lbs/acre of tall fesue 30 lbs/acre of wheat 25 lbs/acre of unhulled bermuda
SEEDING DATES	March 15 – September 15	September 15 – March 15
SEEDING AMENDMENTS	Apply lime and fertilizer per soil tests, or 4000 lbs/acre limestone and 1000 lbs/acre 10-10-10 fertilizer.	Apply lime and fertilizer per soil tests, or 4000 lbs/acre limestone and 1000 lbs/acre 10-10-10 fertilizer.

STABILIZATION TIMEFRAMES

<u>SITE AREA DESCRIPTION</u>	<u>STABILIZATION</u>	<u>TIMEFRAME EXCEPTIONS</u>
PERIMETER DIKES, SWALES, DITCHES, SLOPES	7 DAYS	NONE
HIGH QUALITY WATER (HQW) ZONES	7 DAYS	NONE
SLOPES STEEPER THAN 3:1	7 DAYS	IF SLOPES ARE 10' OR LESS IN LENGTH AND ARE NOT STEEPER THAN 2:1, 14 DAYS ARE ALLOWED
SLOPES 3:1 OR FLATTER	14 DAYS	7 DAYS FOR SLOPES GREATER THAN 50' IN LENGTH
ALL OTHER AREAS WITH SLOPES FLATTER THAN 4:1	14 DAYS	NONE, EXCEPT FOR PERIMETERS AND HQW ZONES



ENGINEERING DIVISION
433 HAY ST. 28301
(910) 433-1656
<http://www.fayettevillenc.gov>

PERMANENT SEEDING SCHEDULE

Rev. Date: 16JAN18
Not to Scale

EC-7

EARLY SUMMER SEASON

FALL/WINTER SEASON

SEEDING MIXTURE	40 lbs/acre of German millet 80 lbs/acre of tall fesue	120 lbs/acre Rye (grain) 80 lbs/acre tall fesue
SEEDING DATES	May 1 – August 15 Refertilize if growth is not fully adequate. Apply 4000 lbs/acre straw or equivalent hydroseeding.	October 25 – December 30 Between December 30 – February 15, add 50 lbs/acre of annual Kobe lespedeza. Apply 4000 lbs/acre straw or equivalent hydroseeding.
SEEDING AMENDMENTS	Apply lime and fertilizer per soil tests, or 2000 lbs/acre limestone and 750 lbs/acre 10-10-10 fertilizer.	Apply lime and fertilizer per soil tests, or 2000 lbs/acre limestone and 750 lbs/acre 10-10-10 fertilizer.



ENGINEERING DIVISION
433 HAY ST. 28301
(910) 433-1656
<http://www.fayettevillenc.gov>

TEMPORARY SEEDING SCHEDULE
(SEASONAL)

Rev. Date: 16JAN18
Not to Scale

EC-8

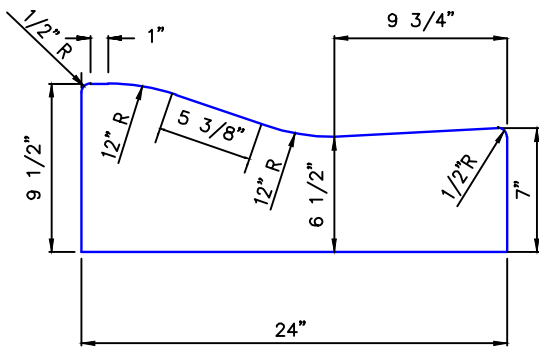

TYPICAL 24" ROLL-BACK CURB

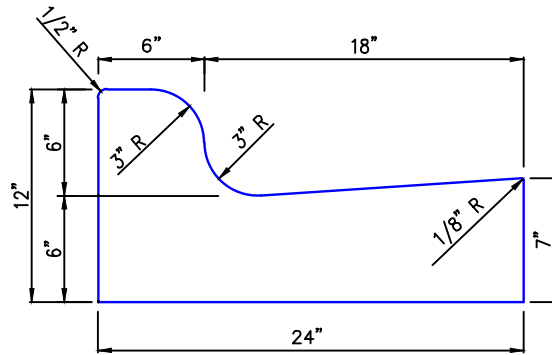

TYPICAL 24" VERTICAL CURB

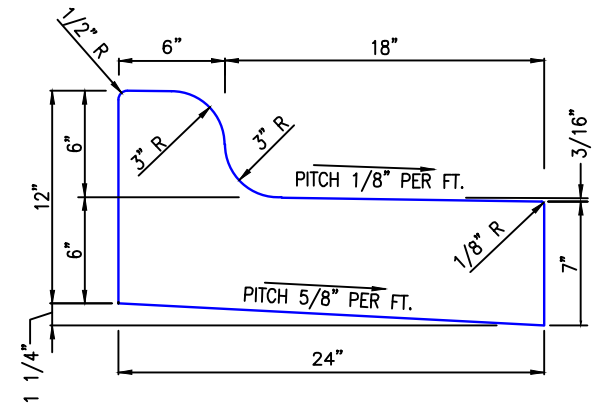

TYPICAL 24" SPILL-OFF CURB

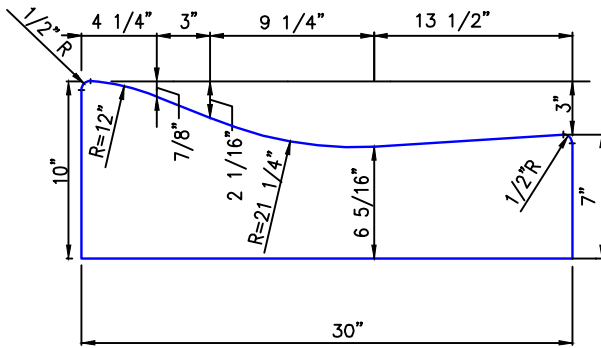

TYPICAL 30" ROLL CURB

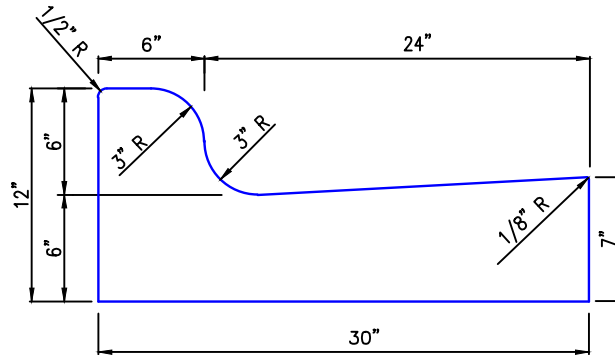

TYPICAL 30" VERTICAL CURB

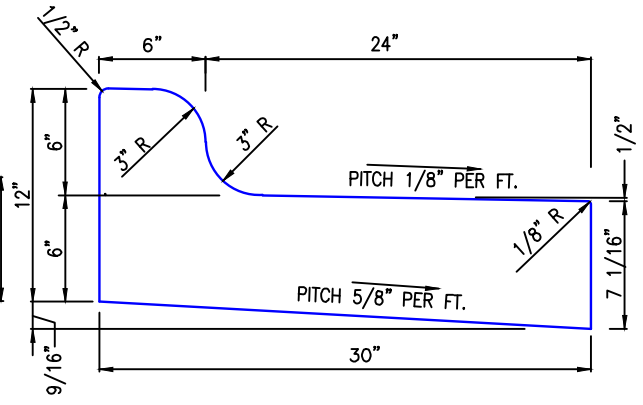

TYPICAL 30" SPILL-OFF CURB

NOTES:

1. ALL CURBS CONSTRUCTED OF 3000 PSI CONCRETE.
2. CONTRACTION JOINTS EVERY 10'; EXPANSION JOINTS EVERY 30'.
3. CURB SHALL BE DEPRESSED AT INTERSECTIONS TO PROVIDE FOR FUTURE ACCESSIBLE RAMPS.
4. TOP 6" OF SUBGRADE BENEATH THE CURB AND GUTTER SHALL BE COMPACTED TO 100% STANDARD PROCTOR DENSITY.

Fayetteville
North Carolina

ENGINEERING DIVISION
433 HAY ST. 28301
(910) 433-1656
<http://www.fayettevillenc.gov>

**24" AND 30"
CURB DETAILS**

Rev. Date: 16JAN18
Not to Scale

SD-1

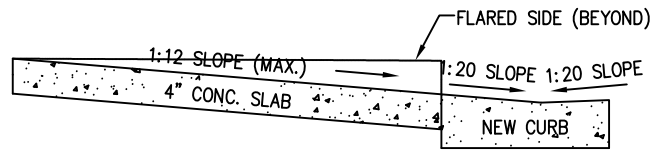

TYP. ROLL CURB SECTION AT HANDICAP RAMP

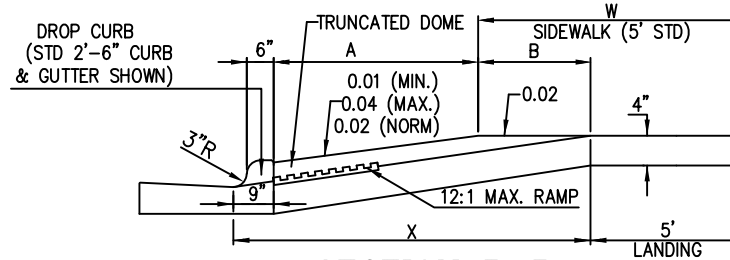

SECTION B-B

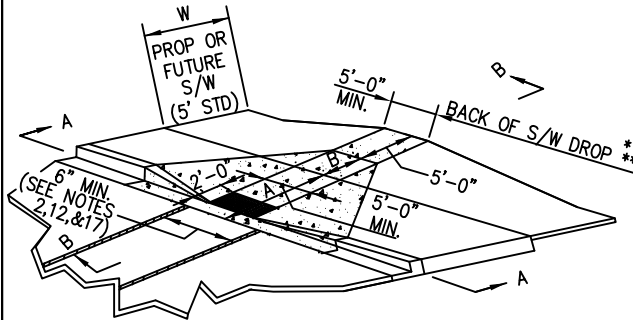

ISOMETRIC VIEW

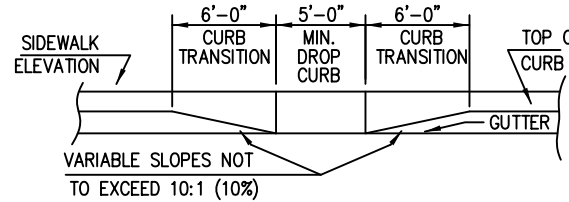

SECTION A-A

W	A	W + A + 9"	X	B	Y
5'	2.0'	7.8'	7.8'	5.0'	7.8'
5'	2.5'	8.3'	8.1'	4.8'	8.1'
5'	3.0'	8.8'	8.3'	4.4'	8.3'
5'	3.5'	9.3'	8.4'	4.1'	8.4'
5'	4.0'	9.8'	8.6'	3.8'	8.6'
5'	4.5'	10.3'	8.7'	3.4'	8.7'
5'	5.0'	10.8'	8.9'	3.1'	8.9'

$B = X - (A + 9")$

B = DISTANCE FROM FRONT EDGE OF SIDEWALK TO BACK POINT OF 12:1 (8.33%) SLOPE.

* BACK OF SIDEWALK DROP REQUIRED FOR ALL SIDEWALK SLOPES.

** BACK OF SIDEWALK DROP REQUIRED FOR SIDEWALK SLOPES 0.04.

NOTES:

1. A PORTION OF ONE OR BOTH RAMPS MAY EXTEND OUTSIDE THE CURB RETURN.
2. PLACE EXPANSION JOINT ON ALL SIDES WHERE SIDEWALK ABUTS RAMP.

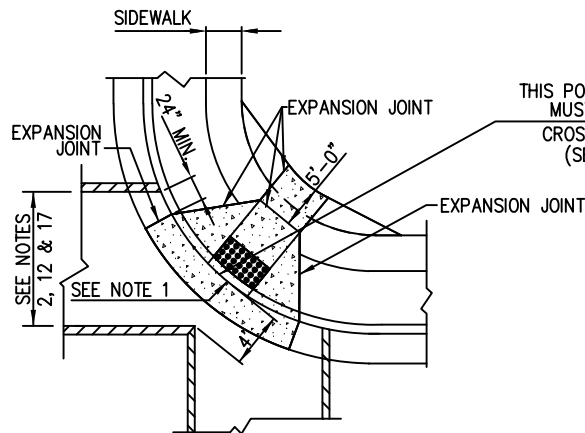

PLAN VIEW

DIAGONAL RAMP
MAX. 25' RADIUS
(60" MIN. FLOOR WIDTH)
[NOT PERMISSIBLE FOR NEW CONSTRUCTION]

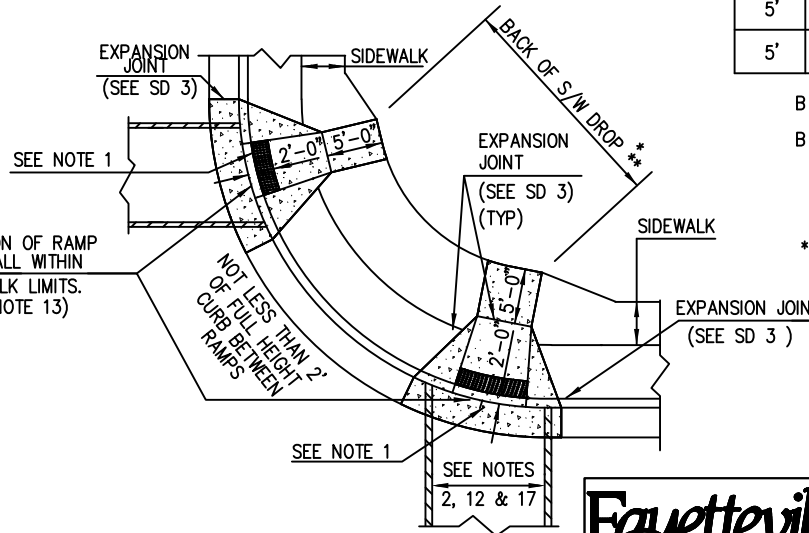

PLAN VIEW

DUAL RAMPS
ANY RADIUS
(40" MIN. FLOOR WIDTH)

SEE SHEET SD-2.3 FOR WHEELCHAIR RAMP NOTES.

Fayetteville
North Carolina

ENGINEERING DIVISION
433 HAY ST. 28301
(910) 433-1656
<http://www.fayettevillenc.gov>

**WHEELCHAIR RAMP W/
SIDEWALK OFF BACK OF CURB**

Rev. Date: 01MAY18
Not to Scale

SD-2

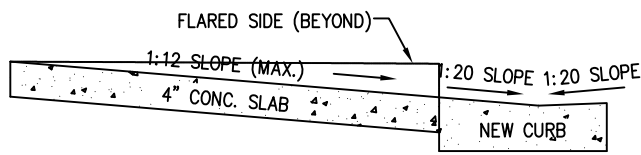

**TYP. ROLL CURB SECTION
AT HANDICAP RAMP**

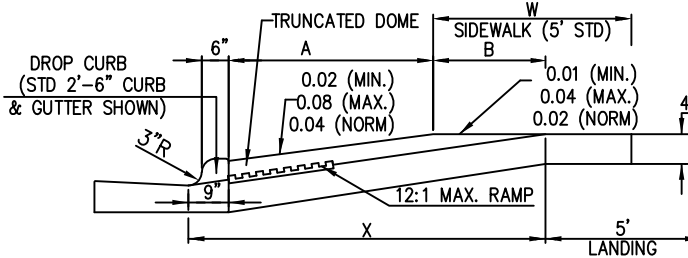

SECTION B-B

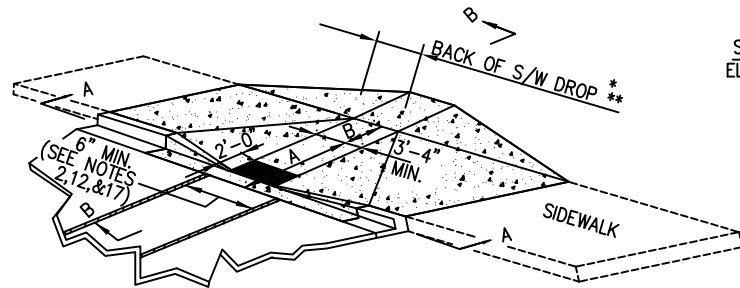

ISOMETRIC VIEW

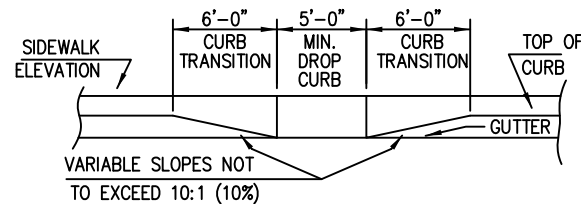

SECTION A-A

W	A	W + A + 9"	X	B
5'	0.0'	5.8'	5.8'	5.0' *
6'	0.0'	6.8'	6.8'	6.0' **
7'	0.0'	7.8'	7.3'	6.5' **
8'	0.0'	8.8'	7.3'	6.5' **
5'	2.0'	7.8'	7.8'	5.0'
5'	2.5'	8.3'	8.1'	4.8'
5'	3.0'	8.8'	8.3'	4.4'
5'	3.5'	9.3'	8.4'	4.1'
5'	4.0'	9.8'	8.6'	3.8'
5'	4.5'	10.3'	8.7'	3.4'
5'	5.0'	10.8'	8.9'	3.1'

$B = X - (A + 9")$

B = DISTANCE FROM FRONT EDGE OF SIDEWALK TO BACK POINT OF 12:1 (8.33%) SLOPE.

* BACK OF SIDEWALK DROP REQUIRED FOR ALL SIDEWALK SLOPES.

** BACK OF SIDEWALK DROP REQUIRED FOR SIDEWALK SLOPES 0.04.

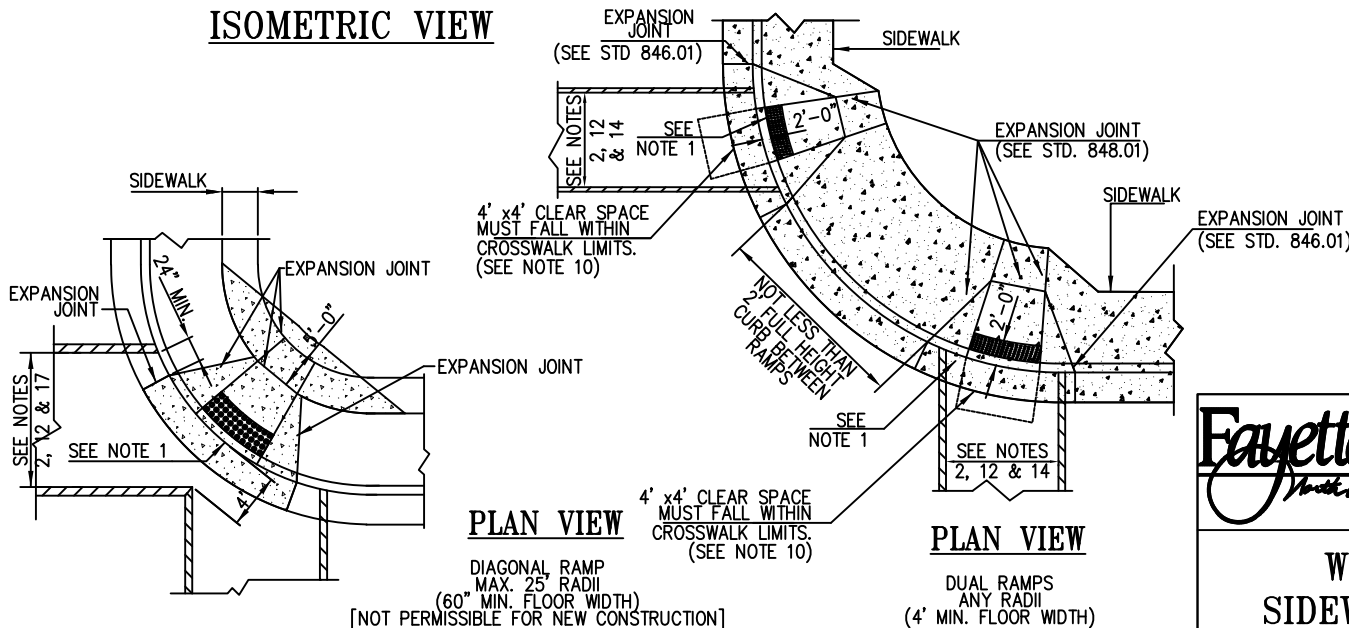

PLAN VIEW

DIAGONAL RAMP
MAX. 25 RADII
(60" MIN. FLOOR WIDTH)
[NOT PERMISSIBLE FOR NEW CONSTRUCTION]

PLAN VIEW

DUAL RAMPS
ANY RADII
(4' MIN. FLOOR WIDTH)

- NOTE: 1. A PORTION OF ONE OR BOTH RAMPS MAY EXTEND OUTSIDE THE RETURN.
2. PLACE EXPANSION JOINT ON ALL SIDES WHERE SIDEWALK ABUTS RAMP.



ENGINEERING DIVISION
433 HAY ST. 28301
(910) 433-1656
<http://www.fayettevillenc.gov>

**WHEELCHAIR RAMP W/
SIDEWALK ON BACK OF CURB**

Rev. Date: 01MAY18
Not to Scale

SD-2.1

SEE SHEET SD-2.3 FOR WHEELCHAIR RAMP NOTES.

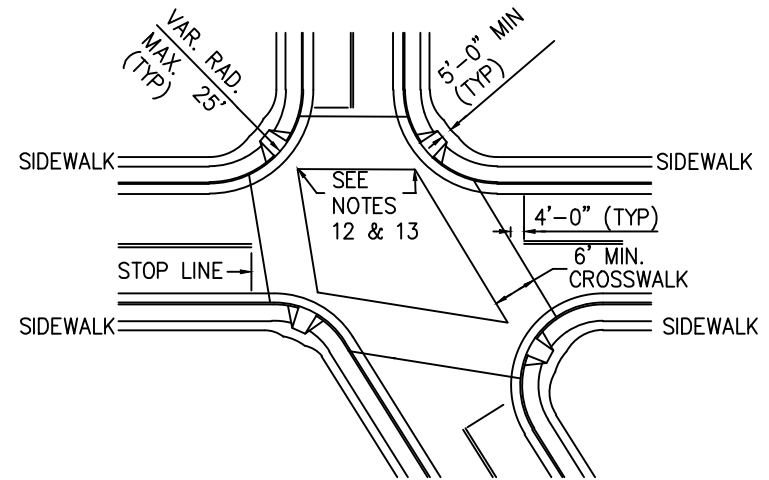
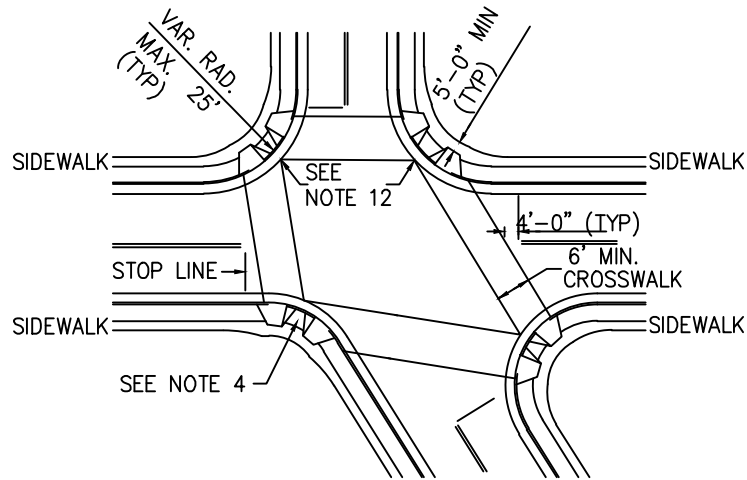

TYPICAL INTERSECTIONS

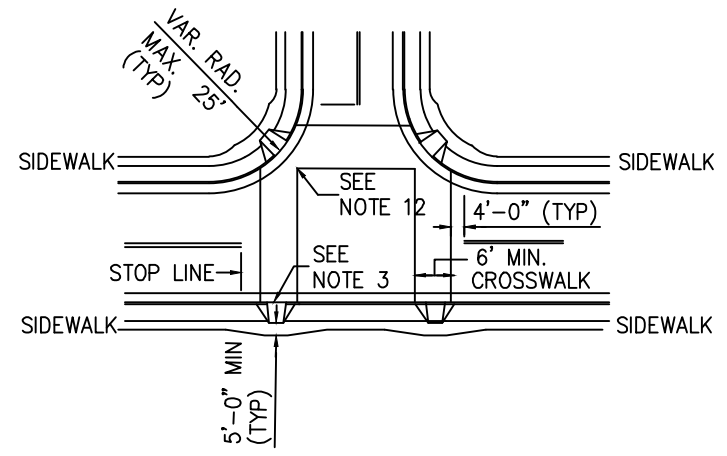
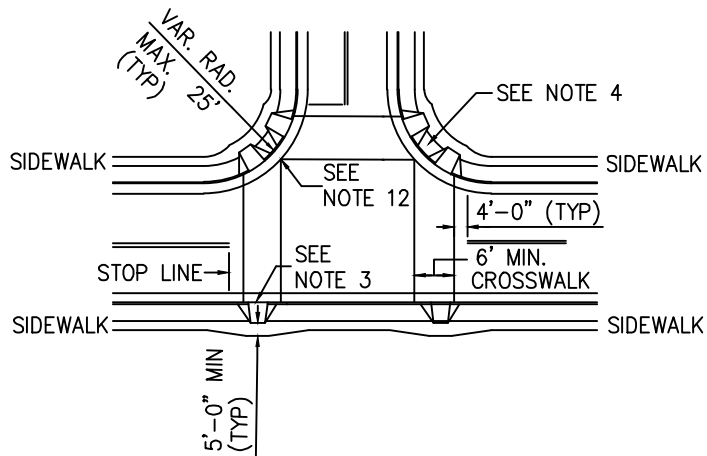

TEE INTERSECTIONS

ALLOWABLE LOCATIONS

DUAL RAMP RADII.....ANY
 DIAGONAL RAMP RADII...MAX. 25'
 (DIAGONAL RAMP IS NOT
 PERMISSIBLE FOR NEW
 CONSTRUCTION)

SEE SHEET SD-2.3 FOR WHEELCHAIR RAMP NOTES.



ENGINEERING DIVISION
 433 HAY ST. 28301
 (910) 433-1656
<http://www.fayettevillenc.gov>

**WHEELCHAIR RAMP WITH PEDESTRIAN
 CROSSWALKS AND STOP LINES**

Rev. Date: 16JAN18
 Not to Scale

SD-2.2

1. CONSTRUCT THE WALKING SURFACE WITH SLIP RESISTANCE AND A 70% CONTRASTING COLOR TO THE SIDEWALK. WHEELCHAIR RAMP SHALL ALSO INCLUDE A BLACK, TRUNCATED DOME STRIP.
2. CROSSWALK WIDTHS AND CONFIGURATION VARY BUT MUST CONFORM TO TRAFFIC DESIGN STANDARDS.
3. NORTH CAROLINA GENERAL STATUTE 136-44.14 REQUIRES THAT ALL STREET CURBS BEING CONSTRUCTED OR RECONSTRUCTED FOR MAINTENANCE PROCEDURES, TRAFFIC OPERATIONS, REPAIRS, CORRECTION OF UTILITIES OR ALTERED FOR ANY REASON AFTER SEPTEMBER 1, 1973 SHALL PROVIDE WHEELCHAIR RAMPS FOR THE PHYSICALLY DISABLED AT ALL INTERSECTIONS WHERE BOTH CURB AND GUTTER AND SIDEWALKS ARE PROVIDED AND AT OTHER POINTS OF PEDESTRIAN FLOW.

IN ADDITION, SECTION 228 OF THE 1973 FEDERAL AID HIGHWAY SAFETY ACT REQUIRES PROVISION OF CURB RAMPS ON ANY CURB CONSTRUCTION AFTER JULY 1, 1976 WHETHER A SIDEWALK IS PROPOSED INITIALLY OR IS PLANNED FOR A FUTURE DATE.

THE AMERICANS WITH DISABILITIES ACT (ADA) OF 1990 EXTENDS TO INDIVIDUALS WITH DISABILITIES. COMPREHENSIVE CIVIL RIGHTS PROTECTIONS SIMILAR TO THOSE PROVIDED TO PERSONS ON THE BASIS OF RACE, SEX, NATIONAL ORIGIN AND RELIGION UNDER THE CIVIL RIGHTS ACT OF 1964. THESE CURB RAMPS HAVE BEEN DESIGNED TO COMPLY WITH THE CURRENT ADA STANDARDS.

4. PROVIDE WHEELCHAIR RAMPS AT LOCATIONS AS SHOWN ON THE PLANS OR AS DIRECTED BY THE ENGINEER. LOCATE WHEELCHAIR RAMPS AS DIRECTED BY THE ENGINEER WHERE EXISTING LIGHT POLES, FIRE HYDRANTS, DROP INLETS, ETC. AFFECT PLACEMENT. WHERE TWO RAMPS ARE INSTALLED NOT LESS THAN 2 FEET OF FULL HEIGHT CURB SHALL BE PLACED BETWEEN THE RAMPS. PLACE DUAL RAMPS AS NEAR PERPENDICULAR TO THE TRAVEL LANE BEING CROSSED AS POSSIBLE.
5. PAY FOR ALL VARIABLE DEPTH CONCRETE USED FOR CONSTRUCTION OF WHEELCHAIR RAMPS AS CONCRETE WHEELCHAIR RAMPS AS DESCRIBED ON PROJECT SPECIFICATIONS.
6. PAY FOR ALL DEPRESSED CURBS AT WHEELCHAIR RAMPS AS THE TYPE CURB AND GUTTER USED ADJACENT TO DEPRESSED CURB. (LN. FT.)
7. SUCH PRICES AND PAYMENTS WILL BE CONSIDERED FULL COMPENSATION FOR ALL MATERIALS, LABOR, EQUIPMENT, TOOLS AND INCIDENTALS NECESSARY TO SATISFACTORILY COMPLETE THE WORK.
8. DO NOT EXCEED 0.08 (1:12) SLOPE ON THE WHEELCHAIR RAMP IN RELATIONSHIP TO THE GRADE OF THE STREET.
9. CONSTRUCT WHEELCHAIR RAMPS 48" (ADA STANDARD) OR GREATER FOR DUAL RAMPS.
10. USE CLASS "B" CONCRETE WITH A SIDEWALK FINISH IN ORDER TO OBTAIN A ROUGH NON-SKID TYPE SURFACE.
11. PLACE A 1/2" EXPANSION JOINT WHERE THE CONCRETE WHEELCHAIR RAMP JOINS THE CURB AND AS SHOWN ON SD-2.
12. PLACE THE INSIDE PEDESTRIAN CROSSWALK LINES NO CLOSER IN THE INTERSECTION BY BISECTING THE INTERSECTION RADII, WITH ALLOWANCE OF A 4' CLEAR ZONE IN THE VEHICULAR TRAVELWAY WHEN ONE RAMP IS INSTALLED. (SEE NOTE 17)
13. COORDINATE THE CURB CUT AND THE PEDESTRIAN CROSSWALK LINES SO THE FLOOR OF THE WHEELCHAIR RAMP WILL FALL WITHIN THE PEDESTRIAN CROSSWALK LINES. PLACE DIAGONAL RAMPS WITH FLARED SIDES SO 24" OF FULL HEIGHT CURB FALLS WITHIN THE CROSSWALK MARKINGS ON EACH SIDE OF THE FLARES.
14. CONSTRUCT THE PEDESTRIAN CROSSWALK A MINIMUM OF 6 FEET. A CROSSWALK WIDTH OF 10 FEET OR GREATER IS DESIRABLE.
15. USE STOP LINES, NORMALLY PERPENDICULAR TO THE LANE LINES, WHERE IT IS IMPORTANT TO INDICATE THE POINT BEHIND WHICH VEHICLES ARE REQUIRED TO STOP IN COMPLIANCE WITH A TRAFFIC SIGNAL, STOP SIGN OR OTHER LEGAL REQUIREMENT. AN UNUSUAL APPROACH SKEW MAY REQUIRE THE PLACEMENT OF THE STOP LINE TO BE PARALLEL TO THE INTERSECTING ROADWAY.
16. TERMINATE PARKING A MINIMUM OF 20 FEET BACK OF PEDESTRIAN CROSSWALK.
17. PLACE ALL PAVEMENT MARKINGS IN ACCORDANCE WITH THE LATEST EDITION OF THE MANUAL OF UNIFORM TRAFFIC CONTROL DEVICES (MUTCD) PUBLISHED BY THE FEDERAL HIGHWAY ADMINISTRATION AND THE NORTH CAROLINA SUPPLEMENT TO THE MUTCD.



ENGINEERING DIVISION
 433 HAY ST. 28301
 (910) 433-1656
<http://www.fayettevillenc.gov>

WHEELCHAIR RAMP NOTES
 SHEET 4 OF 4

Rev. Date: 01MAR18
 Not to Scale

SD-2.3

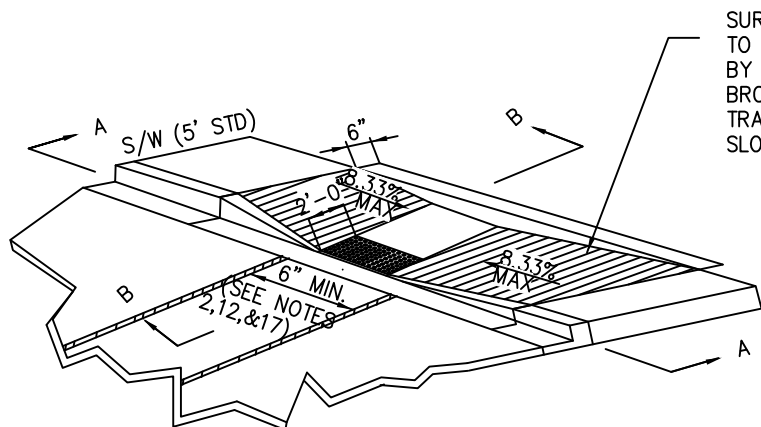

ISOMETRIC VIEW

SURFACE TEXTURE TO BE OBTAINED BY A COARSE BROOMING TRAVERSE TO THE SLOPES OF RAMP.

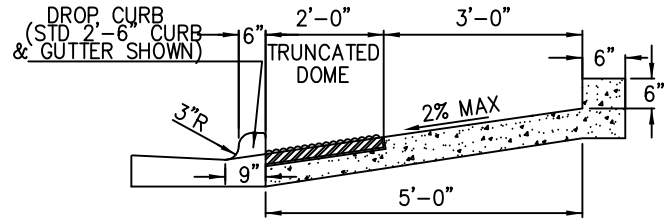

SECTION B-B

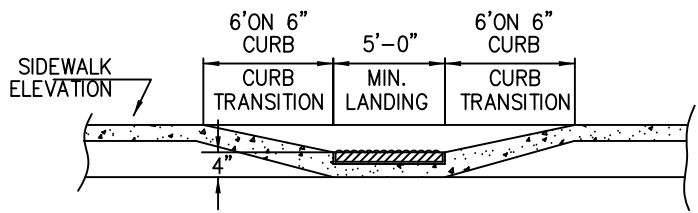

SECTION A-A

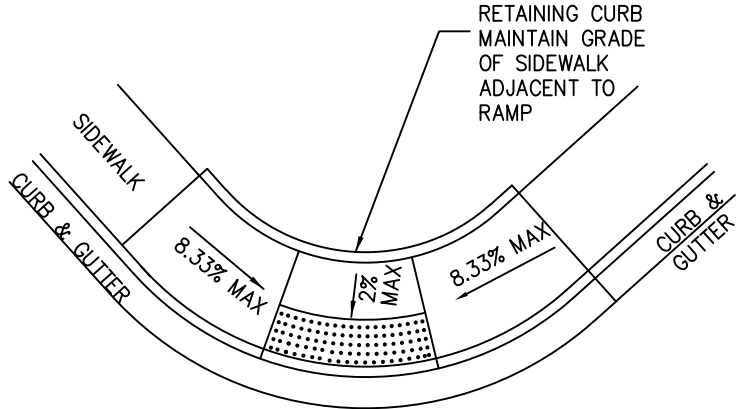

PLAN VIEW

NOTE: WHEN DUAL PARALLEL RAMPS ARE BEING PLACED, A 4' LANDING SHALL BE INSTALLED BETWEEN THE TWO RAMPS.

	ENGINEERING DIVISION 433 HAY ST. 28301 (910) 433-1656 http://www.fayettevillenc.gov

DETAIL OF PARALLEL CURB WHEELCHAIR RAMP

SEE SHEET SD-2.3 FOR WHEELCHAIR RAMP NOTES.

Rev. Date: 01MAY18
Not to Scale

SD-2.4

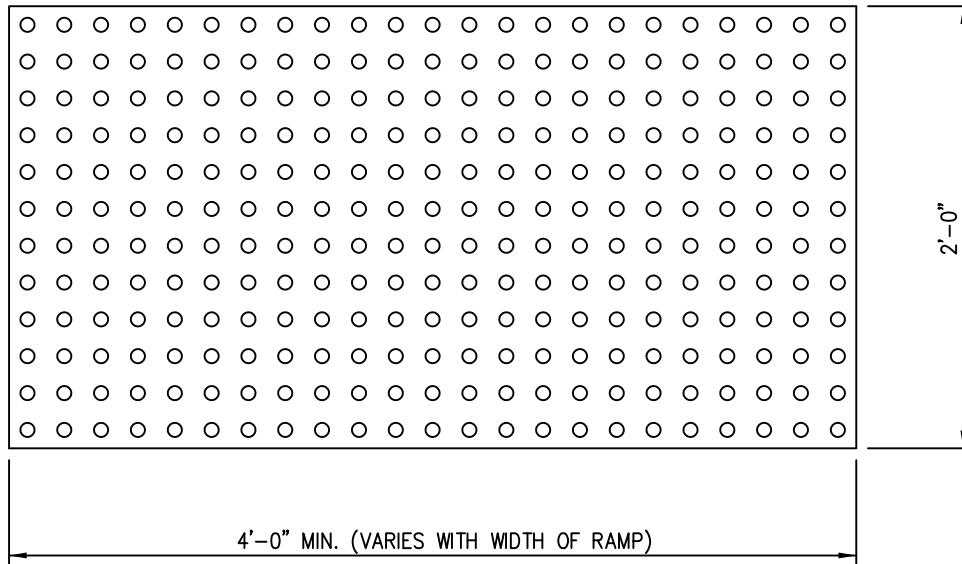

TRUNCATED DOME PLAN VIEW

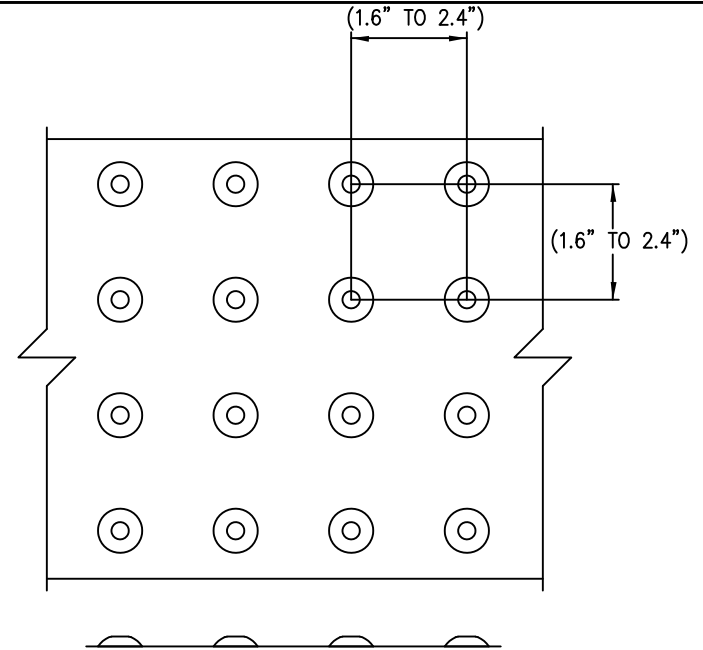

TRUNCATED DOME SPACING

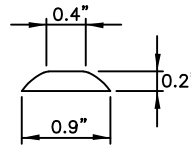

TRUNCATED DOME SECTION

NOTES:

1. ALL DETECTABLE WARNING DEVICES USED IN NEW CONSTRUCTION SHALL BE OF A RIGID PRECAST OR EMBEDDED PRODUCT APPROVED BY THE CITY ENGINEER. RETRO FIT MATS WILL ONLY BE ALLOWED ON EXISTING RAMPS WITH PRIOR APPROVAL OF THE CITY ENGINEER FOR MATERIAL TYPE AND INSTALLATION (I.E. RESURFACING).
2. WIDTH OF DETECTABLE WARNING AREA SHALL BE A MINIMUM OF 4 FEET AND VARY WITH WIDTH OF RAMP.
3. LENGTH OF DETECTABLE WARNING AREA SHALL BE 2 FEET REGARDLESS OF SECTION WIDTH.
4. DETECTABLE WARNING AREA CAN BE SQUARE WHERE USED IN A CURB RADIUS.
5. DETECTABLE WARNING DOMES SHALL BE ALIGNED ON A SQUARE GRID IN THE PREDOMINANT DIRECTION OF TRAVEL TO PERMIT WHEELS TO ROLL BETWEEN DOMES.
6. IF PAVERS ARE TO BE USED, PAVERS SHALL BE 6" THICK AND CAST FROM 5000 psi CONCRETE.
7. MATS ARE TO BE RIGID WITH TURN DOWN EDGES EMBEDDED IN CONCRETE TO ELIMINATE TRIP HAZARD.
8. TRUNCATED DOMES ARE TO BE BLACK IN COLOR.

	ENGINEERING DIVISION 433 HAY ST. 28301 (910) 433-1656 http://www.fayettevillenc.gov
---	---

TRUNCATED DOME DETAILS

Rev. Date: 01MAY18
Not to Scale

SD-2.5

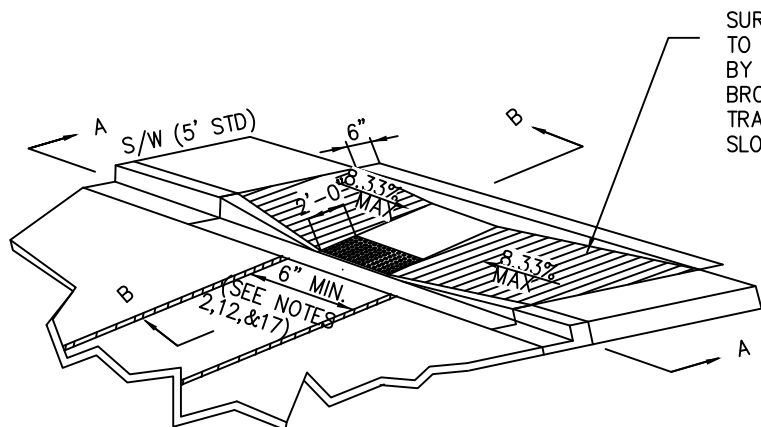

ISOMETRIC VIEW

SURFACE TEXTURE TO BE OBTAINED BY A COARSE BROOMING TRAVERSE TO THE SLOPES OF RAMP.

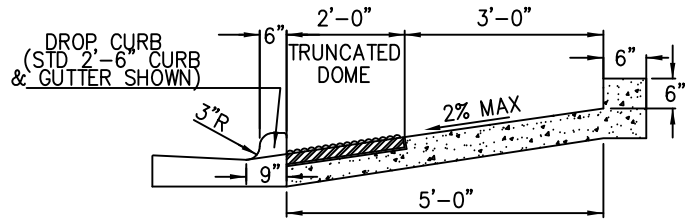

SECTION B-B

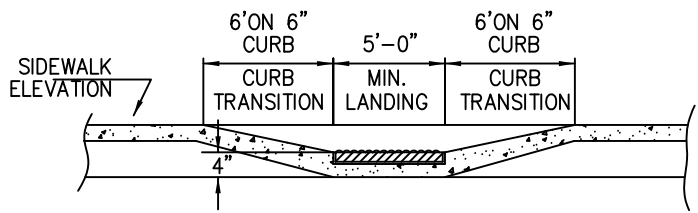

SECTION A-A

RETAINING CURB MAINTAIN GRADE OF SIDEWALK ADJACENT TO RAMP

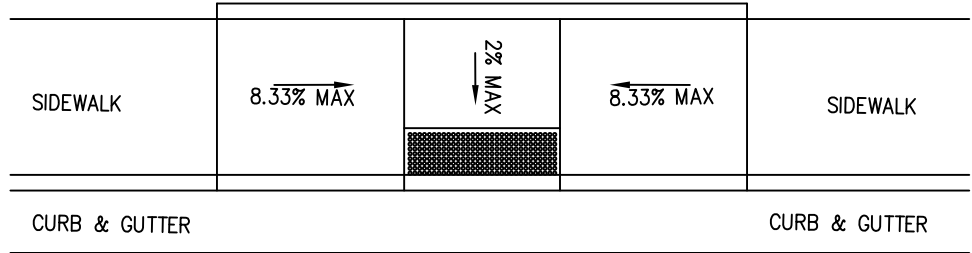

PLAN VIEW

SEE SHEET SD-2.3 FOR WHEELCHAIR RAMP NOTES.

	ENGINEERING DIVISION 433 HAY ST. 28301 (910) 433-1656 http://www.fayettevillenc.gov
	DETAIL OF MID-BLOCK PARALLEL CURB WHEELCHAIR RAMP
Rev. Date: 01MAY18 Not to Scale	SD-2.6

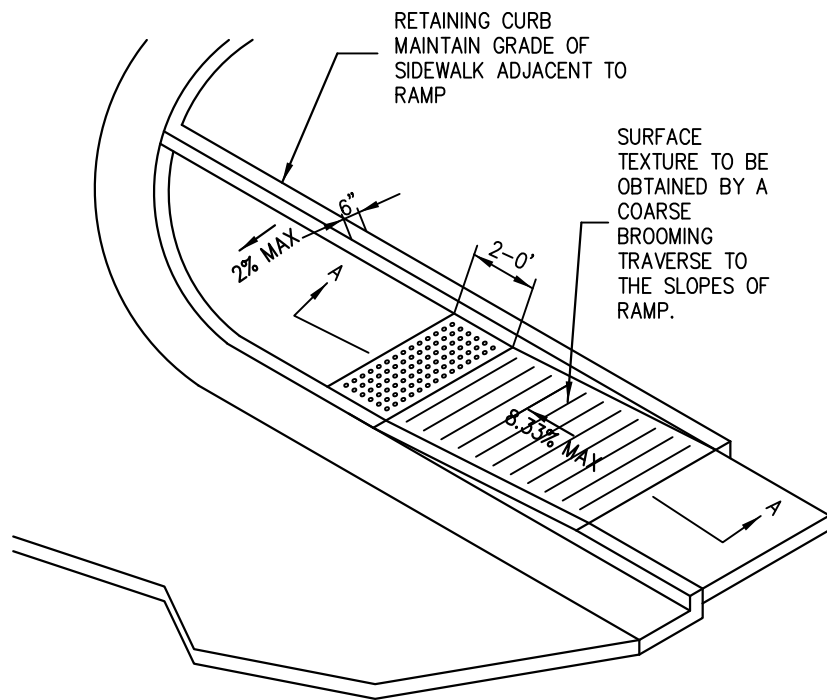

ISOMETRIC VIEW

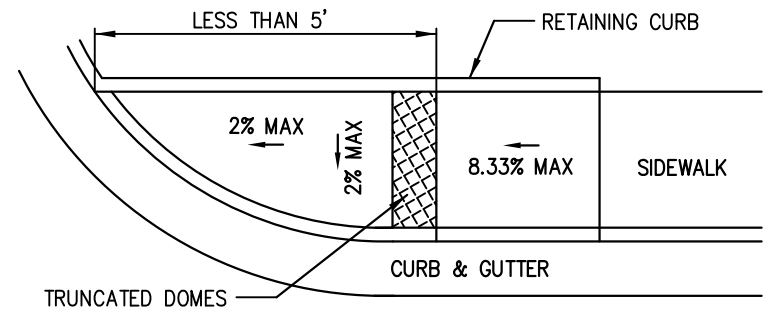

PLAN VIEW 'A'

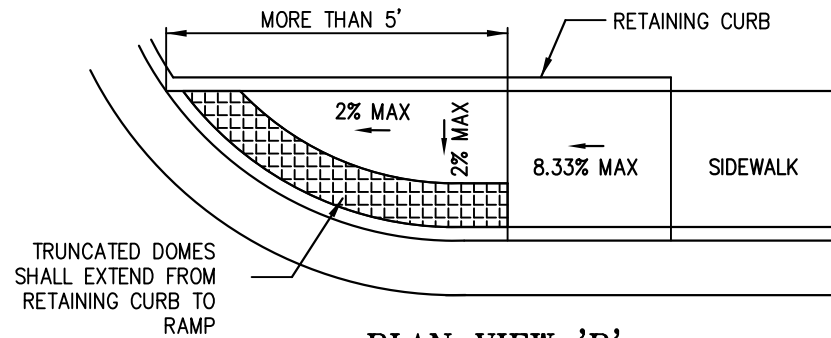

PLAN VIEW 'B'

NOTE:

IF THE DISTANCE BETWEEN THE ROADWAY AND THE RAMP IS LESS THAN 5', THEN TRUNCATED DOMES SHALL BE INSTALLED AS SHOWN IN PLAN VIEW 'A'. WHEN THE DISTANCE IS GREATER THAN 5', TRUNCATED DOMES SHALL BE INSTALLED AS SHOWN IN PLAN VIEW 'B'.

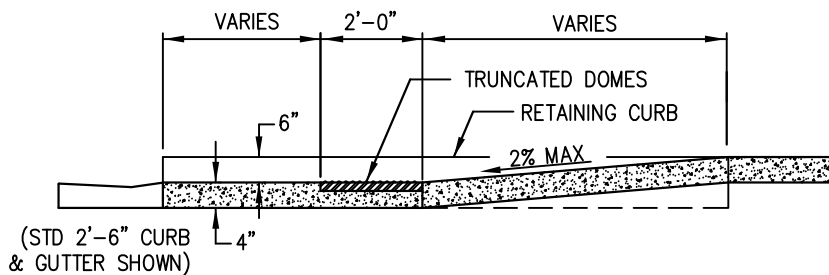

SECTION A-A

SEE SHEET SD-2.3 FOR WHEELCHAIR RAMP NOTES.



ENGINEERING DIVISION
433 HAY ST. 28301
(910) 433-1656
<http://www.fayettevillenc.gov>

DIRECTIONAL CURB RAMP

Rev. Date: 01MAY18
Not to Scale

SD-2.7

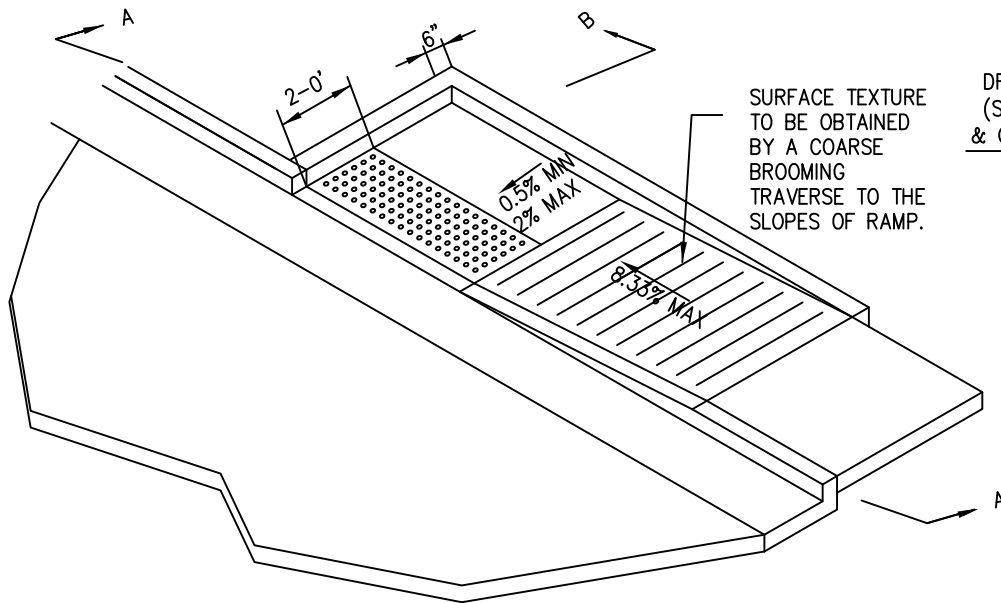

ISOMETRIC VIEW

SURFACE TEXTURE TO BE OBTAINED BY A COARSE BROOMING TRAVERSE TO THE SLOPES OF RAMP.

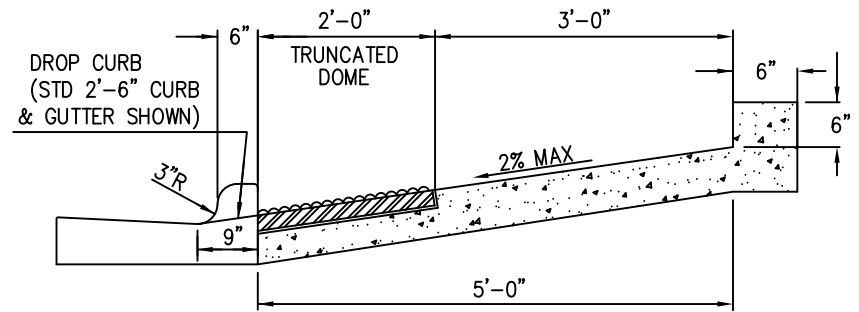

SECTION B-B

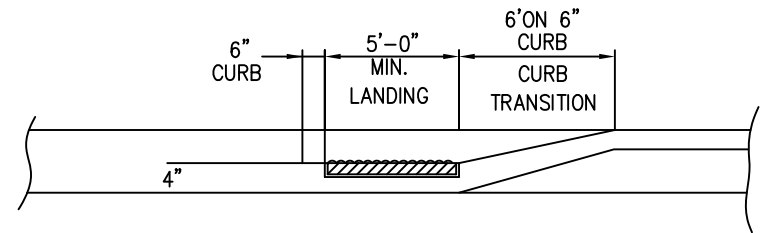

SECTION A-A

RETAINING CURB MAINTAIN GRADE OF SIDEWALK ADJACENT TO RAMP

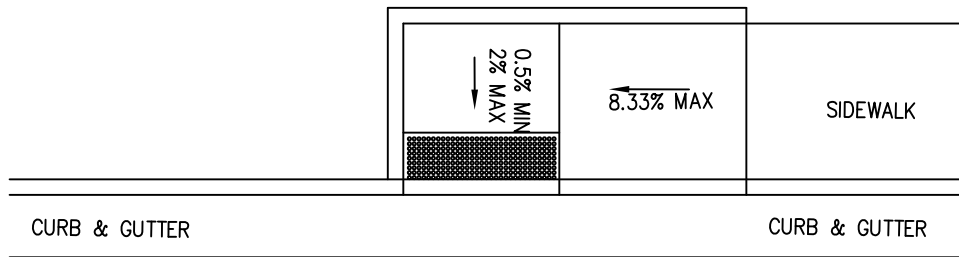

PLAN VIEW

SEE SHEET SD-2.3 FOR WHEELCHAIR RAMP NOTES.



ENGINEERING DIVISION
433 HAY ST. 28301
(910) 433-1656
<http://www.fayettevillenc.gov>

**PARALLEL CURB
SINGLE WING WHEELCHAIR RAMP**

Rev. Date: 01MAY18
Not to Scale

SD-2.8

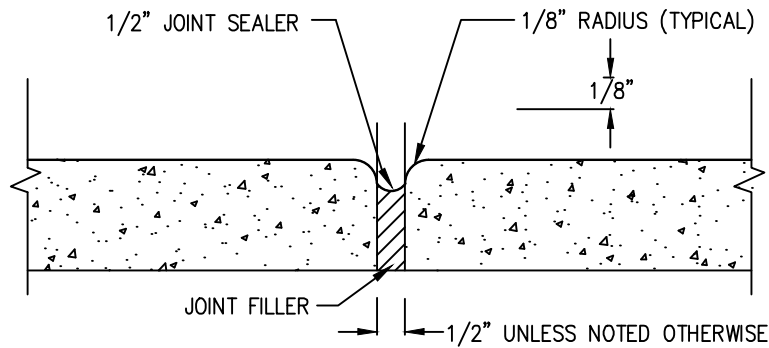

EXPANSION JOINT

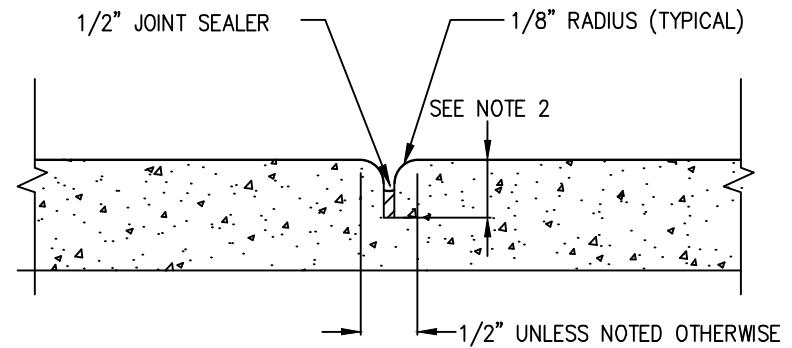

CONTRACTION JOINT

NOTES:

1. CONTRACTION JOINTS IN CURB AND GUTTER SHALL BE SPACED AT 10-FOOT INTERVALS. SIDEWALK CONTRACTION JOINTS SHALL BE SPACED AT 5-FOOT INTERVALS. JOINT SPACING MAY BE ALTERED BY THE CITY ENGINEER TO PREVENT UNCONTROLLED CRACKING.
2. CONTRACTION JOINTS SHALL BE MINIMUM 1" DEEP WHEN INSTALLED BY THE USE OF TEMPLATES OR FORMED BY OTHER APPROVED METHODS. WHERE SUCH JOINTS ARE NOT FORMED BY TEMPLATES, A MINIMUM DEPTH OF 1 1/2" SHALL BE OBTAINED.
3. ALL EXPANSION JOINTS SHALL BE SPACED AT 30-FOOT INTERVALS FOR HAND FORMED, AND ADJACENT TO ALL RIGID OBJECTS. JOINTS SHALL MATCH LOCATIONS WITH JOINTS IN ABUTTING SIDEWALK. IF CURB IS MACHINED A 90' SPACING IS ALLOWABLE
4. REFER TO NCDOT DETAILS 846.01 AND 848.01 FOR MORE INFORMATION.



ENGINEERING DIVISION
 433 HAY ST. 28301
 (910) 433-1656
<http://www.fayettevillenc.gov>

**CONTRACTION AND
 EXPANSION JOINT**

Rev. Date: 16JAN18
 Not to Scale

SD-3

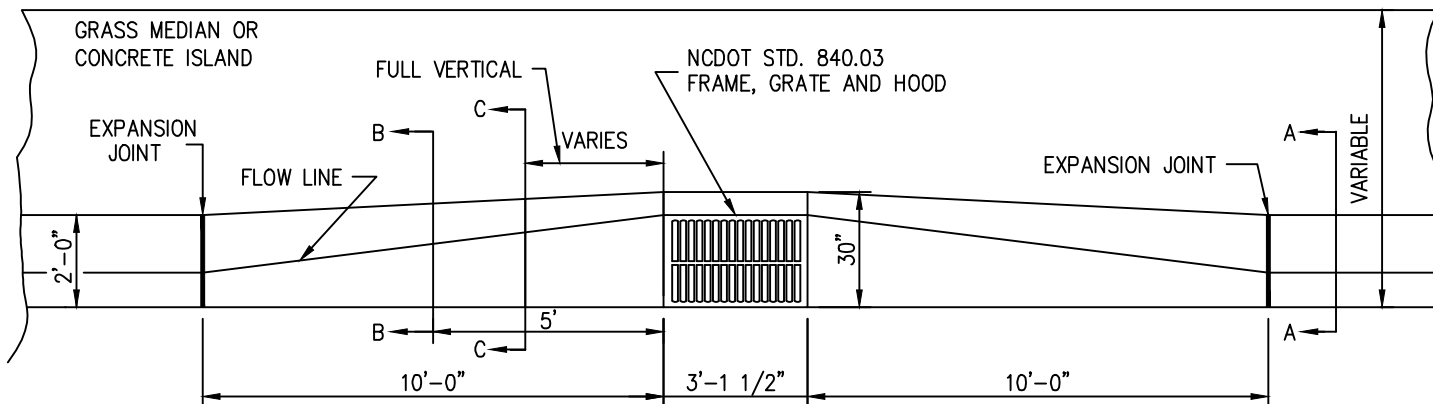

PLAN VIEW

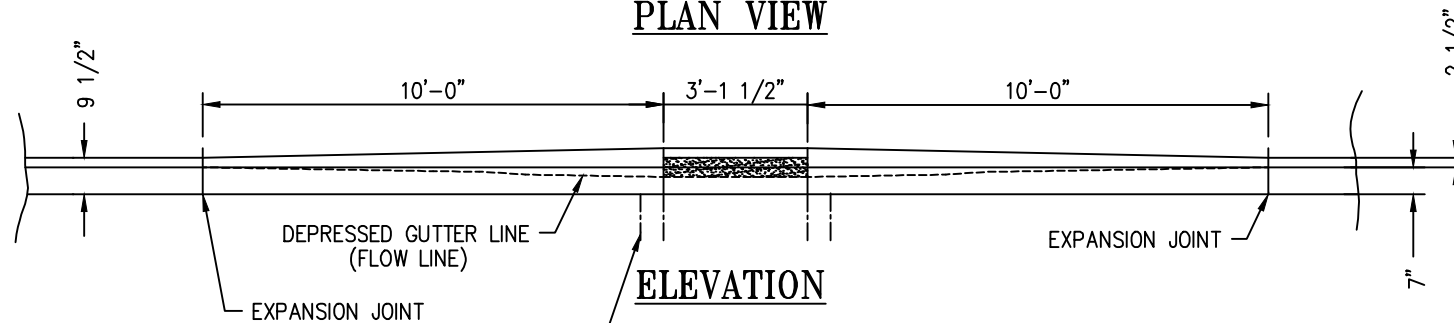

ELEVATION

SEE NCDOT STD. 840.01

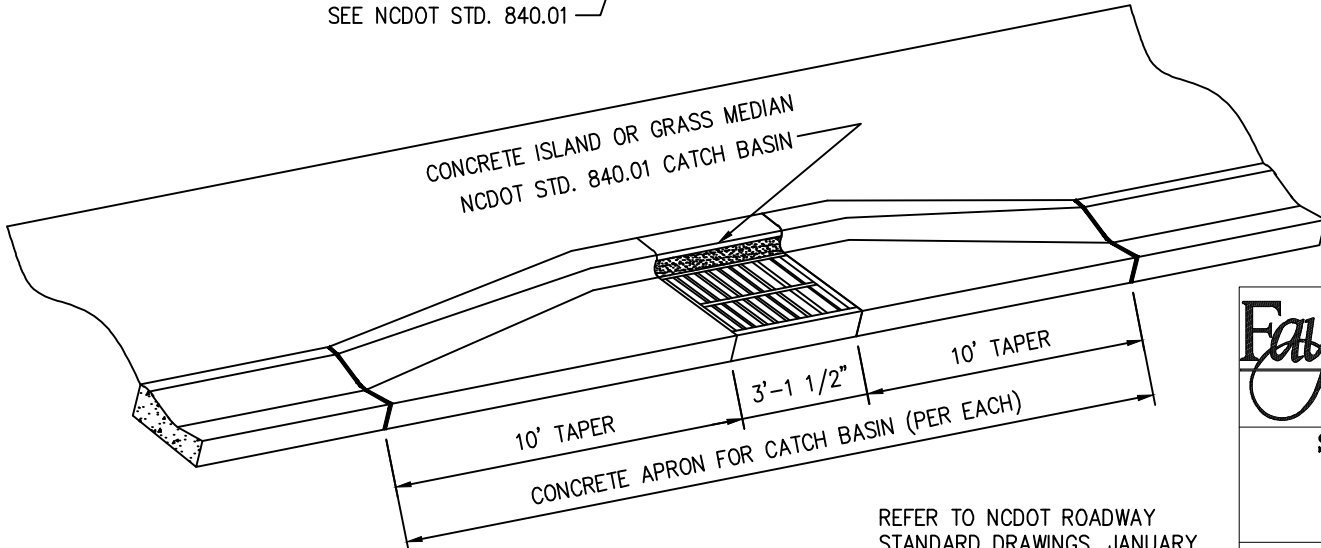

REFER TO NCDOT ROADWAY STANDARD DRAWINGS, JANUARY 2012 OR CURRENT EDITION

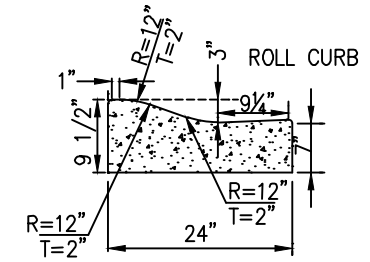

SECTION - AA

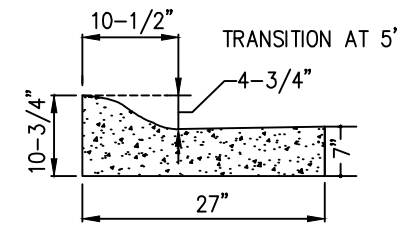

SECTION - BB

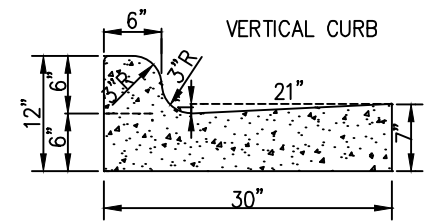

SECTION - CC



ENGINEERING DIVISION
 433 HAY ST. 28301
 (910) 433-1656
<http://www.fayettevillenc.gov>

**STANDARD CATCH BASIN TRANSITION
 FOR 24" ROLL CURB AND GUTTER
 ADOPTED FROM NCDOT
 STANDARD NO. 852.05**

Rev. Date: 16JAN18
 Not to Scale

SD-4

STANDARD CATCH BASIN TRANSITION FOR 24" VERTICAL CURB AND GUTTER

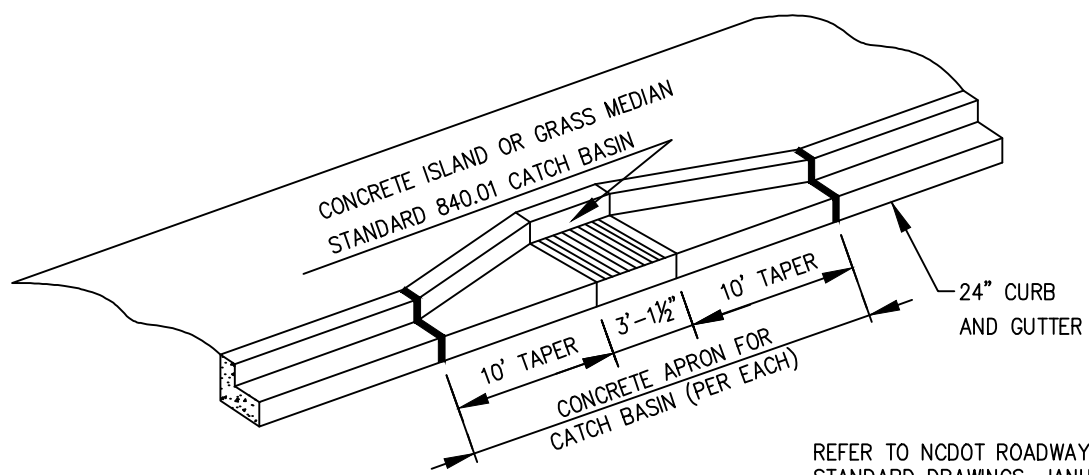
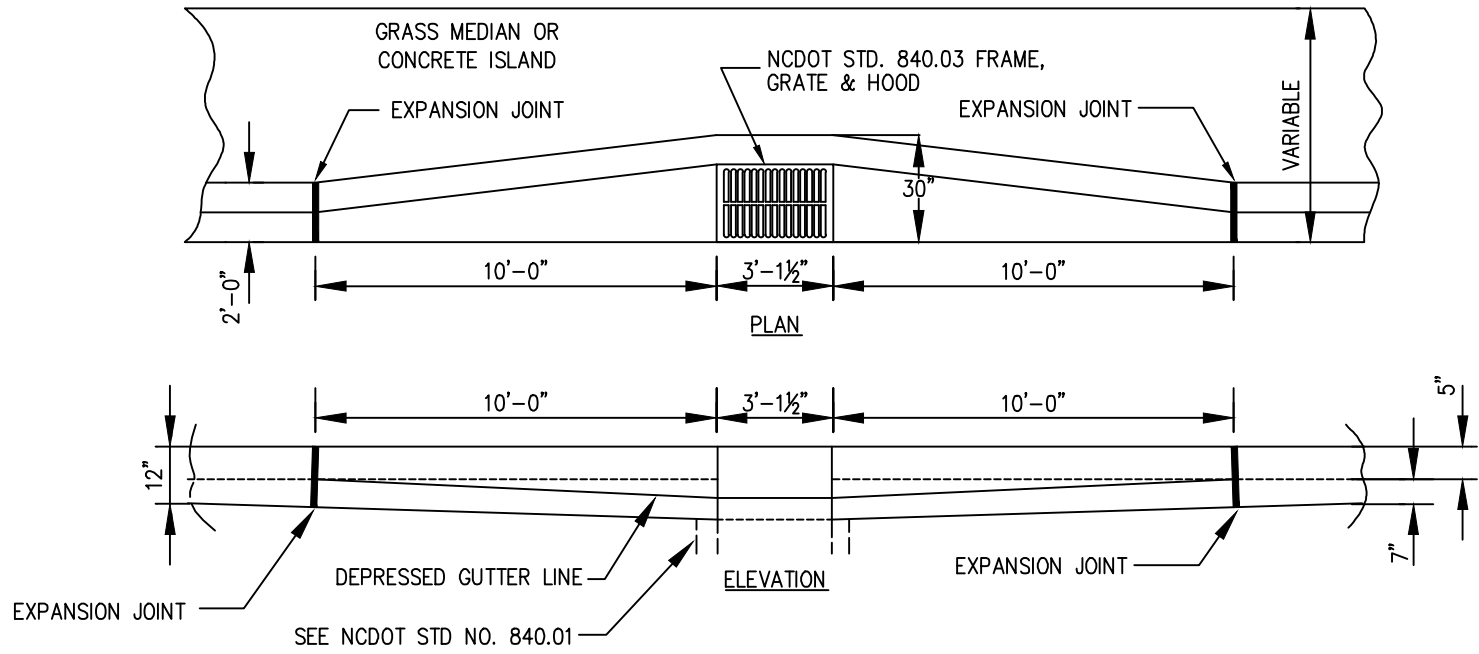

REFER TO NCDOT ROADWAY
STANDARD DRAWINGS, JANUARY
2012 OR CURRENT EDITION

	ENGINEERING DIVISION 433 HAY ST. 28301 (910) 433-1656 http://www.fayettevillenc.gov
	STANDARD CATCH BASIN TRANSITION FOR 24" VERTICAL CURB AND GUTTER ADOPTED FROM NCDOT STANDARD NO. 852.05
Rev. Date: 16JAN18 Not to Scale	SD-5

(CONCRETE PATCH FOR DRIVEWAY UPHILL FROM NEW ASPHALT CURBING)

DETERMINE SAWCUT LOCATION: CHECK SLOPE FROM BACK OF CURBING TO 4' BACK OF CURBING,
IF DIFFERENCE IS 1" TO 3"(1/4" TO 3/4" PER FOOT) CUT AND FORM AT 4' BEHIND BACK OF CURBING.
IF SLOPE IS TOO FLAT OR STEEP, CONSULT INSPECTOR TO DETERMINE SAWCUT.

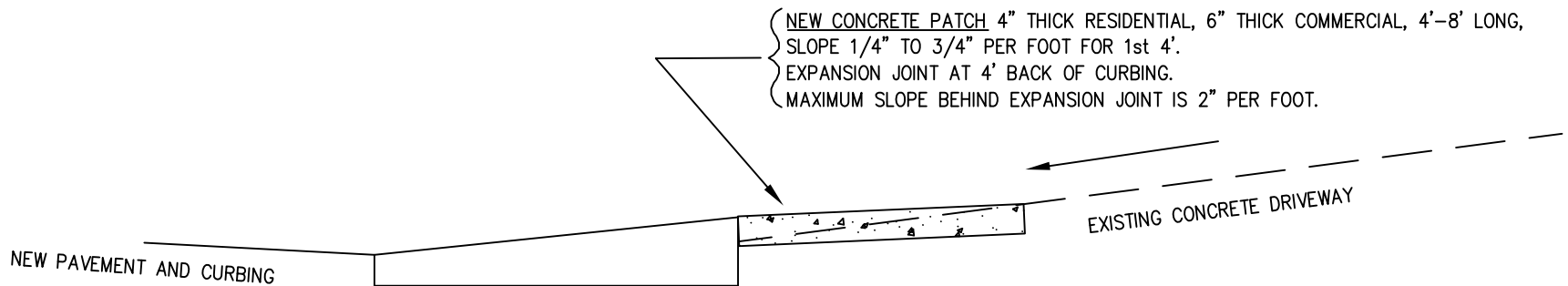

NOTE:

UPHILL DRIVEWAYS: ASPHALT CURB HEIGHT
CAN BE LOWERED TO REDUCE PATCHING NEED.
FOR FURTHER INFORMATION ON DRIVEWAY
CONNECTIONS, CONTACT CONSTRUCTION
MANAGEMENT AT (910) 433-1661.

Fayetteville
North Carolina

ENGINEERING DIVISION
433 HAY ST. 28301
(910) 433-1656
<http://www.fayettevillenc.gov>

**DRIVEWAY CONNECTIONS TO
OVERLAID OR
RAISED CURBING (UPHILL DRIVEWAY)
PAGE 1 OF 2**

Rev. Date: 01MAY18
Not to Scale

SD-6

(CONCRETE PATCH FOR DRIVEWAY DOWNHILL FROM NEW ASPHALT CURBING)

1st CHECK AND MAKE SURE CURB HEIGHT IS 3" MINIMUM

DETERMINE SAWCUT LOCATION: 1st CHECK SLOPE FROM BACK OF CURBING TO TO 4' BACK OF CURBING,
IF DIFFERENCE IS 1" TO 2"(1/4" TO 1/2" PER FOOT) CUT AND FORM AT 4' BEHIND BACK OF CURBING.
IF SLOPE IS TOO FLAT OR STEEP, CONSULT INSPECTOR TO DETERMINE SAWCUT.

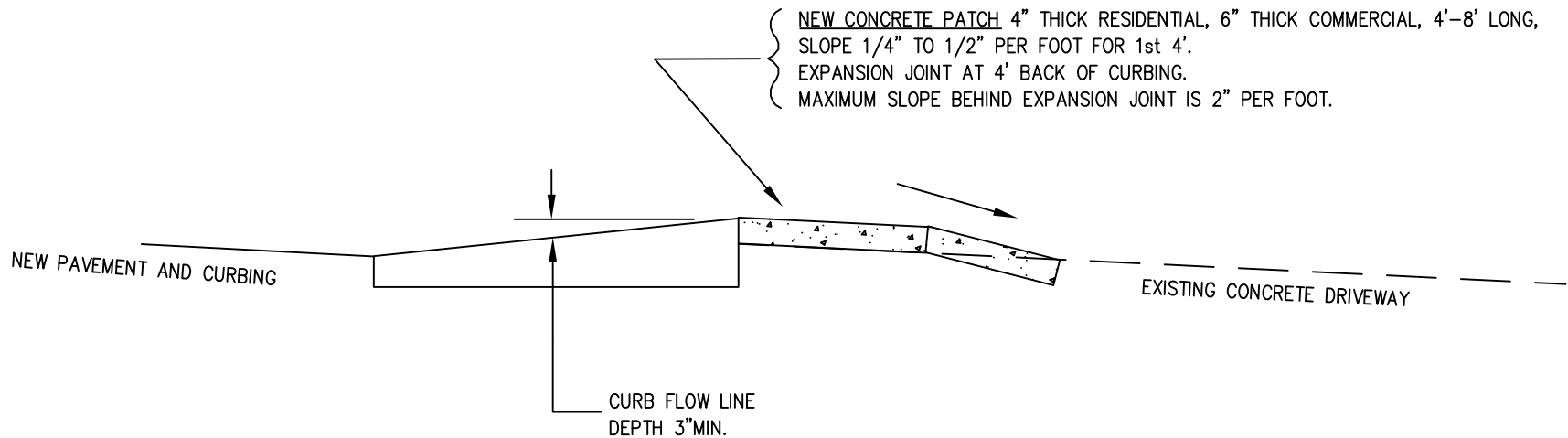

Fayetteville
North Carolina

ENGINEERING DIVISION
433 HAY ST. 28301
(910) 433-1656
<http://www.fayettevillenc.gov>

**DRIVEWAY CONNECTIONS TO
OVERLAID OR
RAISED CURBING (DOWNHILL DRIVEWAY)
PAGE 2 OF 2**

Rev. Date: 01MAY18
Not to Scale

SD-6.1

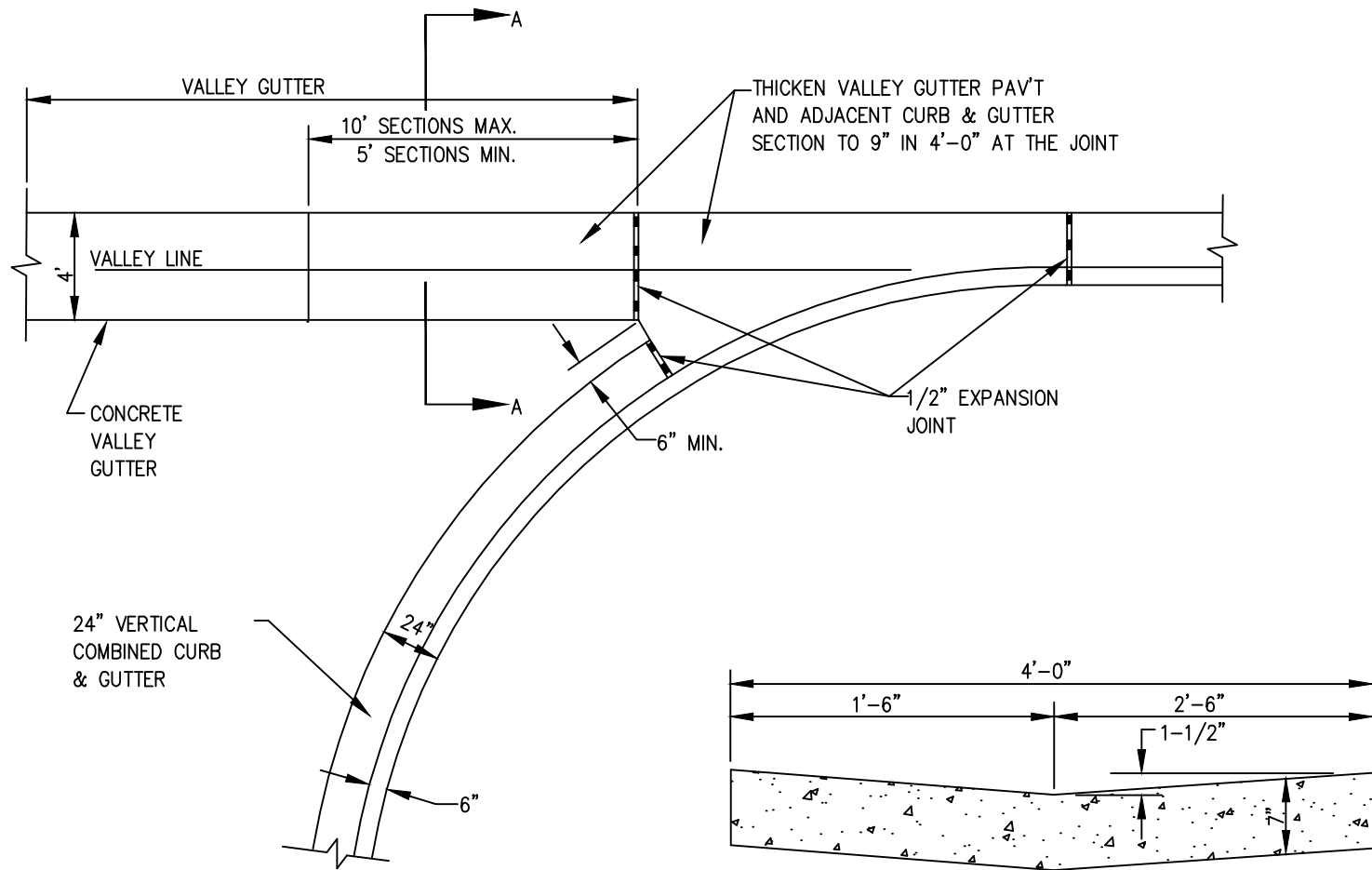

SECTION A-A

NOTE:
TO BE CONSTRUCTED AT ALL INTERSECTIONS
WITH LESS THAN 1% GRADE.

Fayetteville
North Carolina

ENGINEERING DIVISION
433 HAY ST. 28301
(910) 433-1656
<http://www.fayettevillenc.gov>

CONCRETE VALLEY
GUTTER DETAIL

Rev. Date: 16JAN18
Not to Scale

SD-7

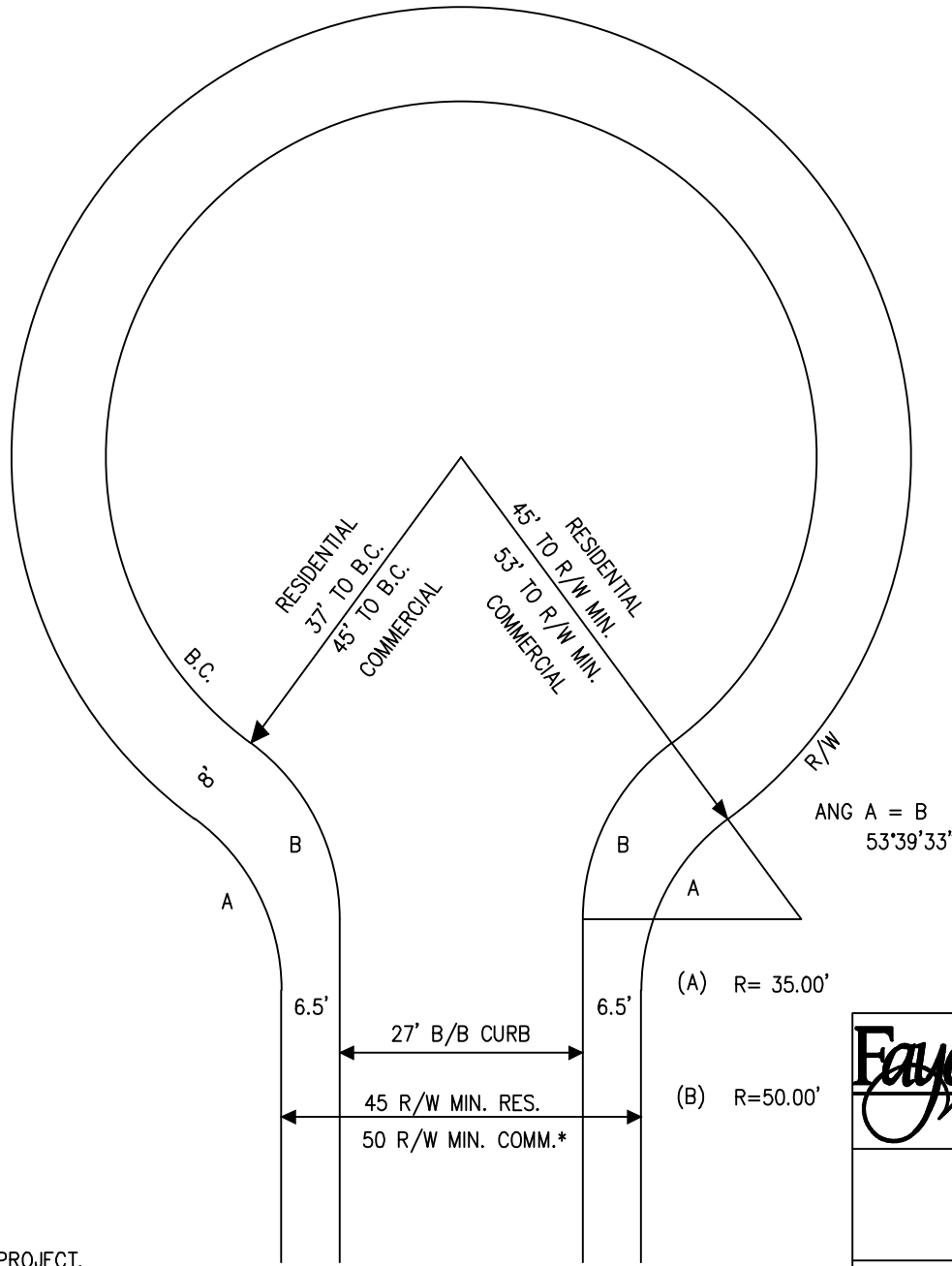

RESIDENTIAL
37' TO B.C.
45' TO B.C.
COMMERCIAL

RESIDENTIAL
45' TO R/W MIN.
53' TO R/W MIN.
COMMERCIAL

ANG A = B
53°39'33"

(A) R= 35.00'

(B) R=50.00'

6.5'

27' B/B CURB

45 R/W MIN. RES.

50 R/W MIN. COMM.*

* MAY VARY DEPENDING ON PROJECT,
SUBJECT TO APPROVAL BY CITY ENGINEER



ENGINEERING DIVISION
433 HAY ST. 28301
(910) 433-1656
<http://www.fayettevillenc.gov>

STANDARD MINIMUMS FOR
RESIDENTIAL AND COMMERCIAL
CUL-DE-SACS

Rev. Date: 16JAN18
Not to Scale

SD-8

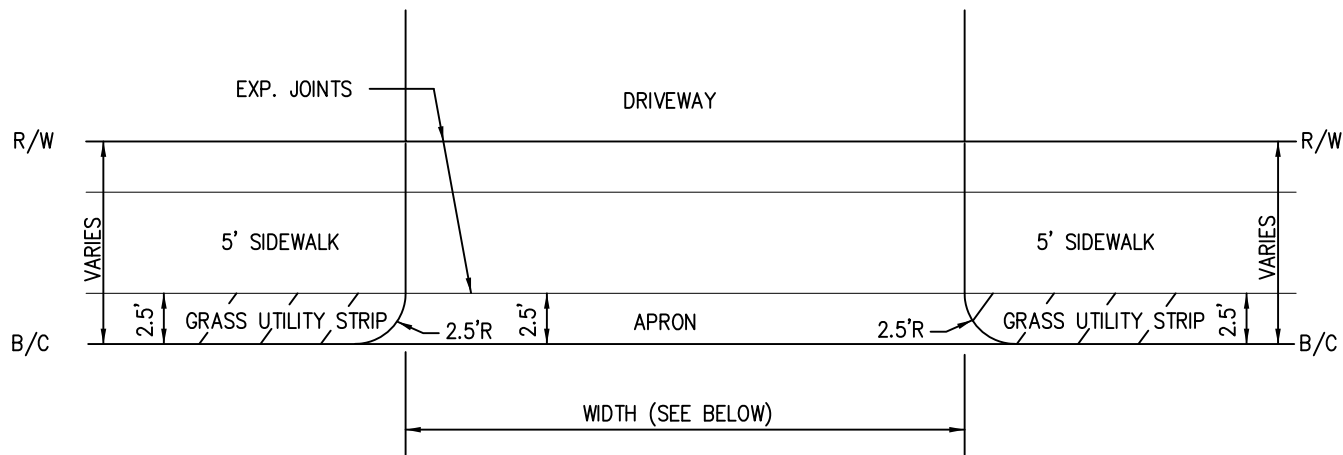

DRIVEWAY APRON

- 12'(MIN) WIDTH
- 20'(MAX) WIDTH (DOUBLE)
- 4" THICK(MIN) CONCRETE

NOTE: DISTANCE FROM B/C TO R/W VARIES ON DIFFERENT STREETS.



ENGINEERING DIVISION
 433 HAY ST. 28301
 (910) 433-1656
<http://www.fayettevillenc.gov>

**TYPICAL RESIDENTIAL
 DRIVEWAY APRON**

Rev. Date: 01MAY18
 Not to Scale

SD-9

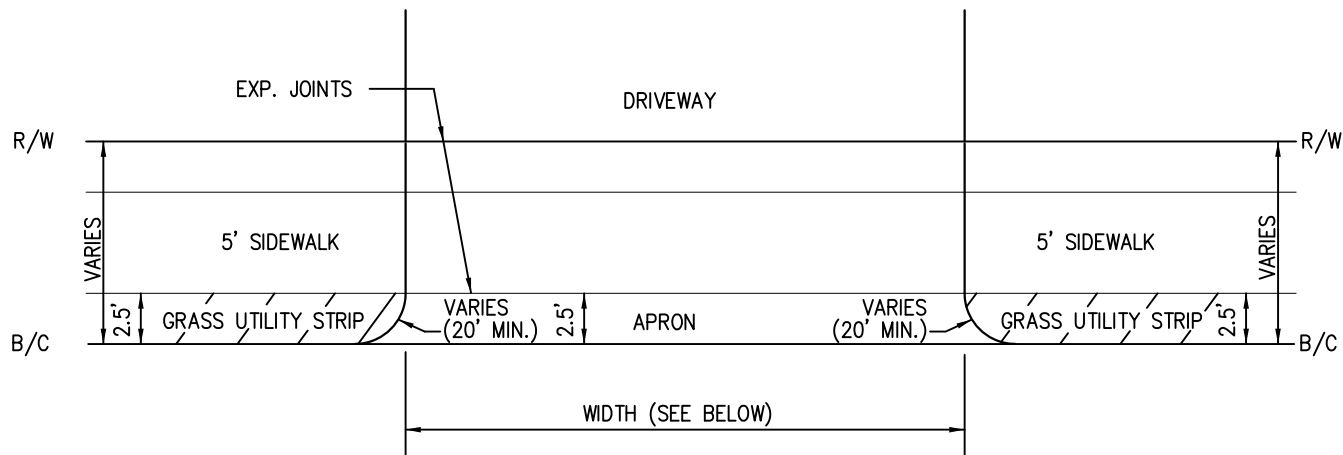

DRIVEWAY APRON

- 20'(MIN) WIDTH
- 36'(MAX) WIDTH (DOUBLE)
- 6" THICK(MIN) CONCRETE

NOTE: DISTANCE FROM B/C TO R/W VARIES ON DIFFERENT STREETS.



ENGINEERING DIVISION
 433 HAY ST. 28301
 (910) 433-1656
<http://www.fayettevillenc.gov>

**TYPICAL COMMERCIAL
 DRIVEWAY APRON**

Rev. Date: 01MAY18
 Not to Scale

SD-9.1

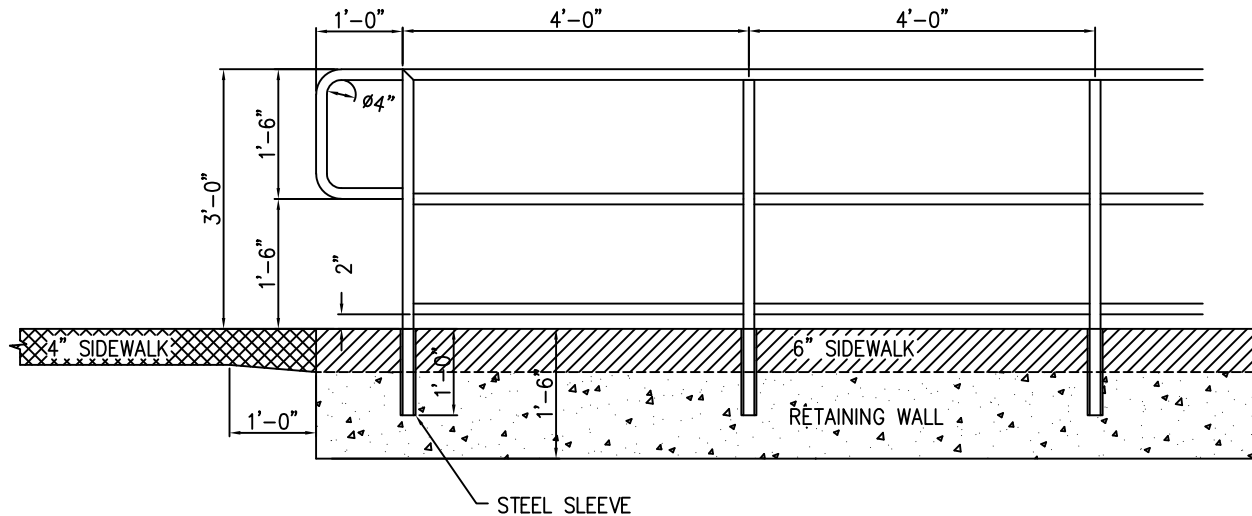

NOTES:

1. HORIZONTAL RAIL TO BE 1-1/4" (ADA) I.D. - SCHEDULE 40-TYPE E, GRADE A OR STRONGER (MIN. YIELD STRESS TO BE 30 KSI, WHICH ALLOWS 21.6 KSI DESIGN STRESS.)
2. POSTS TO BE 1-1/2" I.D. - SCHEDULE 80-TYPE E, GRADE A OR STRONGER (MIN. YIELD STRESS TO BE 30 KSI, WHICH ALLOWS 21.6 KSI DESIGN STRESS.)
3. ALL JOINTS TO BE WELDED AND GROUND TO A SMOOTH SURFACE. PREFABRICATED CONNECTIONS MAY BE USED IF APPROVED BY CITY ENGINEER. WELDS ARE REQUIRED TO MEET AMERICAN WELDING SOCIETY SPECIFICATIONS.
4. POSTS TO EMBEDDED A MIN. OF 12" IN A CORE DRILLED HOLE OR PRESET PIPE SLEEVE. SLEEVE SHALL BE SCHEDULE 40, TYPE E, GRADE A STEEL OR STRONGER.
5. FINISH WITH 1 COAT OF PRIMER AND 2 COATS OF ALL WEATHER ENAMEL USE PAINT. A NEUTRAL COLOR TO BE APPROVED BY PROJECT ENGINEER.
6. CONTRACTOR SHALL WARRANT PAINT AND HANDRAIL FOR 1 YEAR.
7. ANY CHANGES FROM ABOVE RAIL DESIGN SHALL BE SUBMITTED OVER SEAL OF REGISTERED N.C. ENGINEER WITH DESIGN CRITERIA AND STRESS CALCULATIONS.
8. ALL CONCRETE TO BE 3000 PSI COMPRESSIVE STRENGTH
9. STEEL SLEEVE TO ACCOMMODATE 1-1/2" I.D. SCHEDULE 80 TYPE E POST.
10. ALLOW A 12" TRANSITION FROM A 4" SIDEWALK TO A 6" SIDEWALK AND VICE VERSA.



ENGINEERING DIVISION
 433 HAY ST. 28301
 (910) 433-1656
<http://www.fayettevillenc.gov>

PIPE HANDRAIL

Rev. Date: 01MAY18
 Not to Scale

SD-10

SAWCUT ASPH. EDGES STRAIGHT AND TRUE APPROX. 2" DEEP IMMEDIATELY PRIOR TO PATCHING. JAGGED SAWCUTS SHALL NOT BE ACCEPTABLE. STRAIGHT UNIFORM WIDTHS PARALLEL TO THE EDGE OF PAV'T OR CURB ARE REQUIRED. THE FINAL PRODUCT SHALL BE SUBJECT TO THE CITY ENGINEERS APPROVAL.

MAXIMUM "PAYMENT" WIDTH (INFORMATION IS FOR USE ON ANNEXATION PROJECTS ONLY):

- 10' MAX. SANITARY SEWER MAIN (10' OR LESS)
- 12' MAX. SANITARY SEWER MAIN (OVER 10' IN DEPTH)
- 6' MAX. SANITARY SEWER LATERAL 4' MAX. WATER MAIN AND LATERAL (WIDTHS GREATER THAN MAX. WILL NOT BE PAID)

1" MIN. SURFACE COURSE
S 9.5 B - RESIDENTIAL

1 1/2" MIN. SURFACE COURSE
S 9.5 C - LIGHT COMMERCIAL
S 9.5 C - HEAVY COMMERCIAL

EXISTING ASPHALT TO REMAIN.

EXIST. BASE

12" MIN.

6"

EXISTING ASPHALT TO REMAIN.

TACKCOAT (0.25 Gal/sy.)
ALL PAVEMENT EDGES

UNDISTURBED SOIL

LAST 3' OF FILL BELOW SUBGRADE OF STONE SHALL BE COMPACTED TO 98% MAX. DRY DENSITY IN MAX. 6" LOOSE LIFTS.

8" AGGREGATE BASE COURSE COMPACTED TO 100% MAX. DRY DENSITY AS DETERMINED BY AASHTO T-99

6" LIFTS @ 95% COMPACTION

ISOMETRIC

TACKCOAT (TYP.)
(0.25 GAL/SY)

SAW CUT EXISTING ASPHALT EDGES STRAIGHT & TRUE

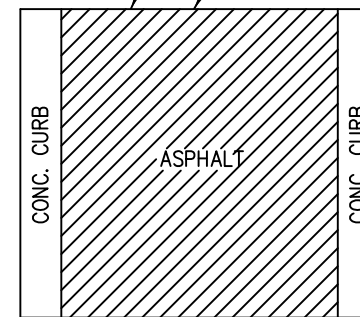

REPLACE CONC. CURB AS NECESSARY (TYP.)

STREET

PLAN

NOTE:

TEMPORARY PATCH IS ONLY ALLOWED TO BE USED IF CONVERTED TO PERMANENT PATCH WITHIN 12 MONTHS. SEE DETAIL SD-11.1

SEE ADDITIONAL NOTES ON DETAIL SD-11.2



ENGINEERING DIVISION
433 HAY ST. 28301
(910) 433-1656
<http://www.fayettevillenc.gov>

TYPICAL TEMPORARY SAWCUT AND PAVEMENT PATCH
PAGE 1 OF 3

Rev. Date: 01MAY18
Not to Scale

SD-11

SAWCUT ASPH. EDGES STRAIGHT AND TRUE APPROX. 2" DEEP IMMEDIATELY PRIOR TO PATCHING. JAGGED SAWCUTS SHALL NOT BE ACCEPTABLE. STRAIGHT UNIFORM WIDTHS PARALLEL TO THE EDGE OF PAV'T OR CURB ARE REQUIRED. THE FINAL PRODUCT SHALL BE SUBJECT TO THE CITY ENGINEERS APPROVAL.

MAXIMUM "PAYMENT" WIDTH (INFORMATION IS FOR USE ON ANNEXATION PROJECTS ONLY):
 10' MAX. SANITARY SEWER MAIN (10' OR LESS)
 12' MAX. SANITARY SEWER MAIN (OVER 10' IN DEPTH)
 6' MAX. SANITARY SEWER LATERAL 4' MAX. WATER MAIN AND LATERAL
 (WIDTHS GREATER THAN MAX. WILL NOT BE PAID)

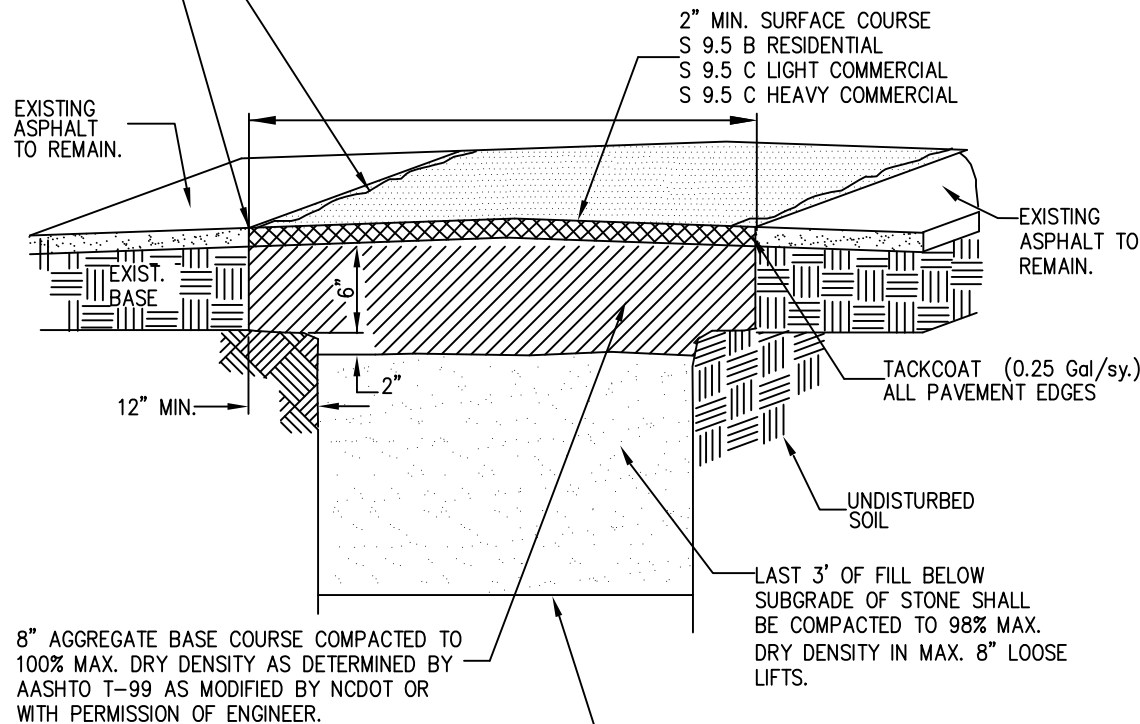

ISOMETRIC

SEE APPLICABLE TRENCH
 DETAIL FOR COMPACTION
 OF REMAINING TRENCH

NOTE:
 SEE DETAIL SD-16.2 FOR TYPICAL CROSS
 SECTION OF PAVEMENT STRUCTURE

SEE ADDITIONAL NOTES ON DETAIL SD-11.2

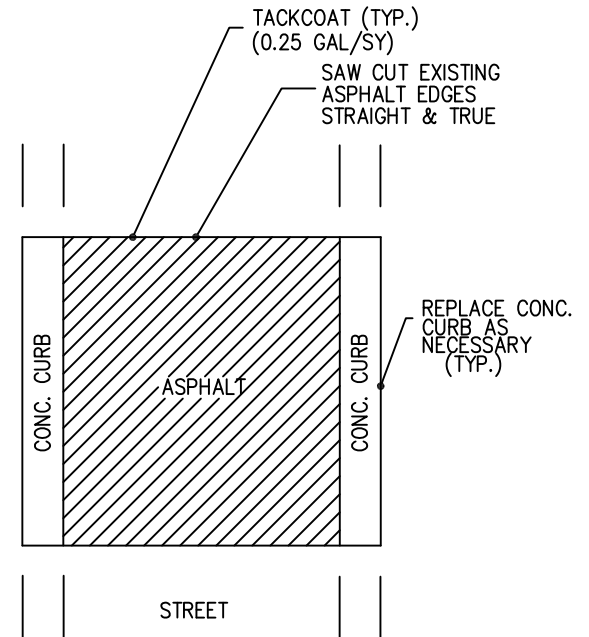

PLAN



ENGINEERING DIVISION
 433 HAY ST. 28301
 (910) 433-1656
<http://www.fayettevillenc.gov>

**TYPICAL PERMANENT SAWCUT
 AND PAVEMENT PATCH
 PAGE 2 OF 3**

Rev. Date: 01MAY18
 Not to Scale

SD-11.1

NOTES:

1. CONTRACTOR SHALL PATCH PAVEMENT TO THE SAME PAVEMENT CROSS SECTION AS EXISTED PRIOR TO REMOVING PAVEMENT. THE STREET CROWN SHALL BE RESTORED. PATCH SHALL MATCH EXISTING PAVEMENT WITHIN .02' WHEN CHECKED WITH A 10' STRAIGHT EDGE. ADJUST PAVER AS REQUIRED. PATCH PAVING MAY OCCUR PRIOR TO PULLING MANDREL THRU SS PROVIDED DENSITY TEST OF TRENCH BACKFILL MEET THE REQUIRED DENSITY AND ENGINEER APPROVES PATCHING STREET PRIOR TO MANDREL TESTING SANITARY SEWER MAIN.
2. WHERE PATCH OF CURBING OCCURS CONTRACTOR SHALL MATCH EXISTING CURB GRADES WITHIN 0.02 FEET. PATCHES THAT ARE ABOVE THE CURB GRADE LINE WILL NOT BE ACCEPTABLE AND SHALL BE REMOVED AND REPATCHED AT NO EXPENSE TO THE OWNER. CURB PATCH SHALL BE THE SAME SHAPE/TEMPLATE AS THE EXISTING CURB.
3. CONTRACTOR SHALL BE REQUIRED TO PROVIDE TRAFFIC CONTROL AND DEVICES AS REQUIRED BY THE MUTCD OR N.C. SUPPLEMENT. WORK CAN NOT PROCEED UNTIL THE MEASURES ARE IN PLACE. CONTRACTOR SHALL BE RESPONSIBLE TO PROTECT NEW PAVEMENT FROM TRAFFIC AND OTHER SOURCES OF DAMAGE UNTIL ASPHALT HAS SUFFICIENTLY COOLED TO PREVENT DAMAGE FROM SURFACE DEFLECTIONS.
4. CONTRACTOR SHALL SAWCUT EXIST. PAVEMENT STRAIGHT AND TRUE PRIOR TO REMOVING ASPHALT FOR UTILITY INSTALLATION. THE ENGINEER MAY APPROVE THE USE OF A MILLING MACHINE FOR REMOVAL OF THE EXISTING PAVEMENT WITHIN TRENCH LIMITS. WHERE MILLING IS APPROVED THE CONTRACTOR SHALL PLACE AND COMPACT MILLINGS IN MILLED AREA TO PROVIDE AN INTERIM TRAFFIC SURFACE. MILLING WHERE APPROVED BY ENGINEER IS AN ALTERNATE TO CUTTING ASPHALT AND DISPOSING OFF-SITE.
- * 5. AFTER UTILITY IS INSTALLED AND TESTED AND THE EXCESS BASE MATERIAL REMOVED (APPROX. 2") CONTRACTOR SHALL AGAIN SAWCUT EXISTING PAVEMENT STRAIGHT AND TRUE IMMEDIATELY PRIOR TO PAVING AS NOTED ABOVE.
6. MILLING OPERATIONS SHALL BE LIMITED TO 1800 FEET PER MAIN LINE CREW NOT TO EXCEED 3000 FEET IN TOTAL OF DISTURBED ROADWAY FOR THE ENTIRE PROJECT AT ONE TIME WHERE. CONTRACTOR SHALL PATCH PAVE DISTURBED AREA OF ROADWAY PRIOR TO DISTURBING ADDITIONAL ROADWAY.
7. AT NO TIME SHALL THE TRENCH BE LEFT UNATTENDED WITH A VERTICAL DROP GREATER THAN 1 INCH FROM ASPHALT SURFACE TO TOP OF BACKFILLED TRENCH.
8. IF PAVEMENT SETTLEMENT OCCURS WITHIN WARRANTY PERIOD (SEE PROJECT SPECIFICATIONS), THE CONTRACTOR SHALL REPATCH AT NO ADDITIONAL EXPENSE TO THE OWNER.
- * 9. NCDOT WILL REQUIRE FULL DEPTH ASPHALT PATCH TO MATCH EXISTING ASPHALT THICKNESS ON STATE MAINTAINED ROADS. NCDOT REQUIRES PATCH PAVING SAME DAY AS REMOVAL.
10. TEST FOR DENSITY OF COMPACTION MAY BE MADE AT THE OPTION OF THE ENGINEER AND DEFICIENCIES SHALL BE CORRECTED BY THE CONTRACTOR AT NO ADDITIONAL COST TO THE OWNER. THE ENGINEER MAY HAVE COMPACTION TEST PERFORMED AFTER THE BACKFILL IS COMPLETE. CONTRACTOR SHALL BE REQUIRED TO EXCAVATE TO VARIOUS ELEVATIONS FOR DENSITY TESTING EXCAVATION, BACKFILL AND RECOMPACTION SHALL BE PERFORMED AT NO ADDITIONAL COSTS TO THE OWNER.

* -- NOTES 5 & 9 APPLY TO PERMANENT PAVEMENT PATCHES ONLY.



ENGINEERING DIVISION
433 HAY ST. 28301
(910) 433-1656
<http://www.fayettevillenc.gov>

**NOTES FOR TYPICAL PERMANENT AND
TEMPORARY SAWCUT AND PAVEMENT PATCH**
PAGE 3 OF 3

Rev. Date: 01MAR18
Not to Scale

SD-11.2

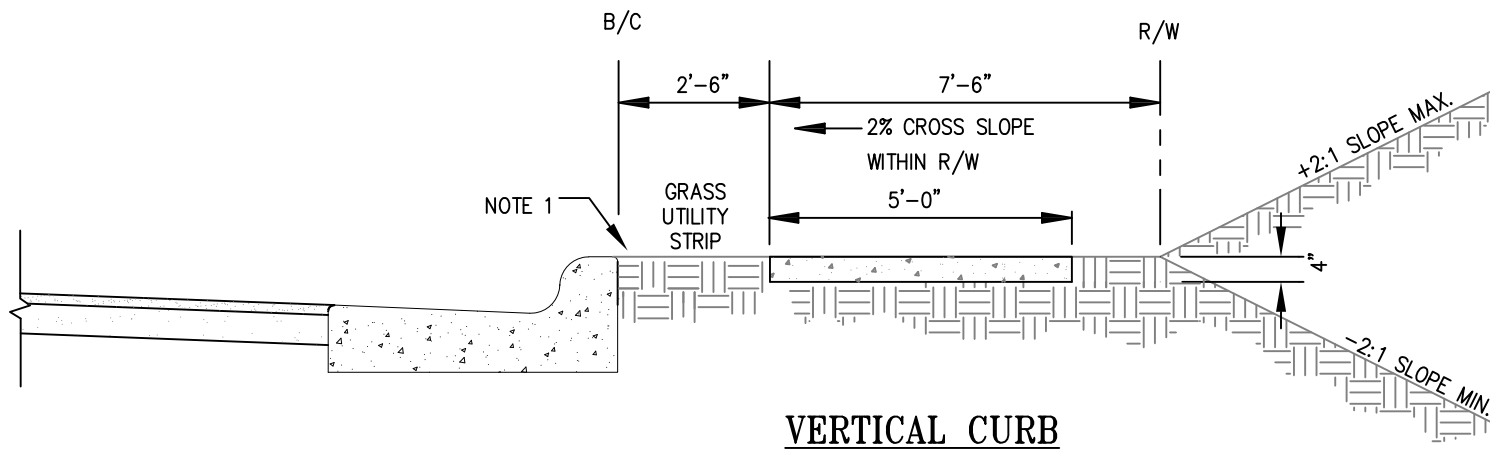
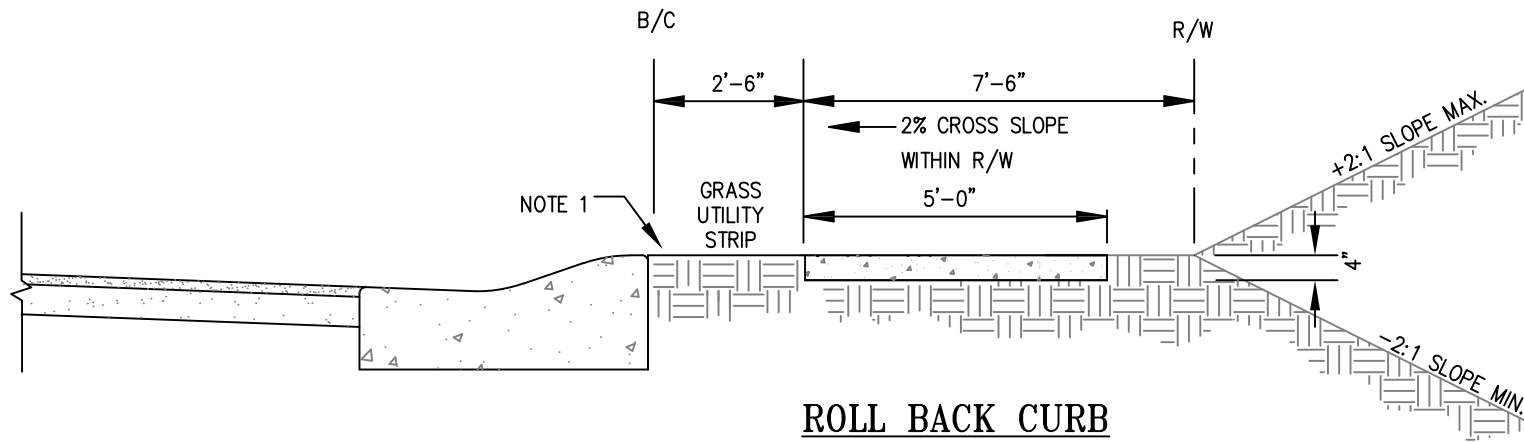

NOTES:

1. VERTICAL CURB – GRASS UTILITY STRIP MAY BE REMOVED UPON APPROVAL OF THE CITY ENGINEER. IF NO GRASS UTILITY STRIP, INSTALL 1/2" EXPANSION JOINT MATERIAL BETWEEN BACK OF CURB AND SIDEWALK.
2. SEE DETAIL SD-3 CONTRACTION AND EXPANSION JOINT.
3. SEE DETAIL SD-9 TYPICAL RESIDENTIAL DRIVEWAY APRON AND DETAIL SD-9.1 TYPICAL COMMERCIAL DRIVEWAY APRON.

Fayetteville
North Carolina

ENGINEERING DIVISION
433 HAY ST. 28301
(910) 433-1656
<http://www.fayettevillenc.gov>

TYPICAL SIDEWALK SECTION

Rev. Date: 01MAY18
Not to Scale

SD-12

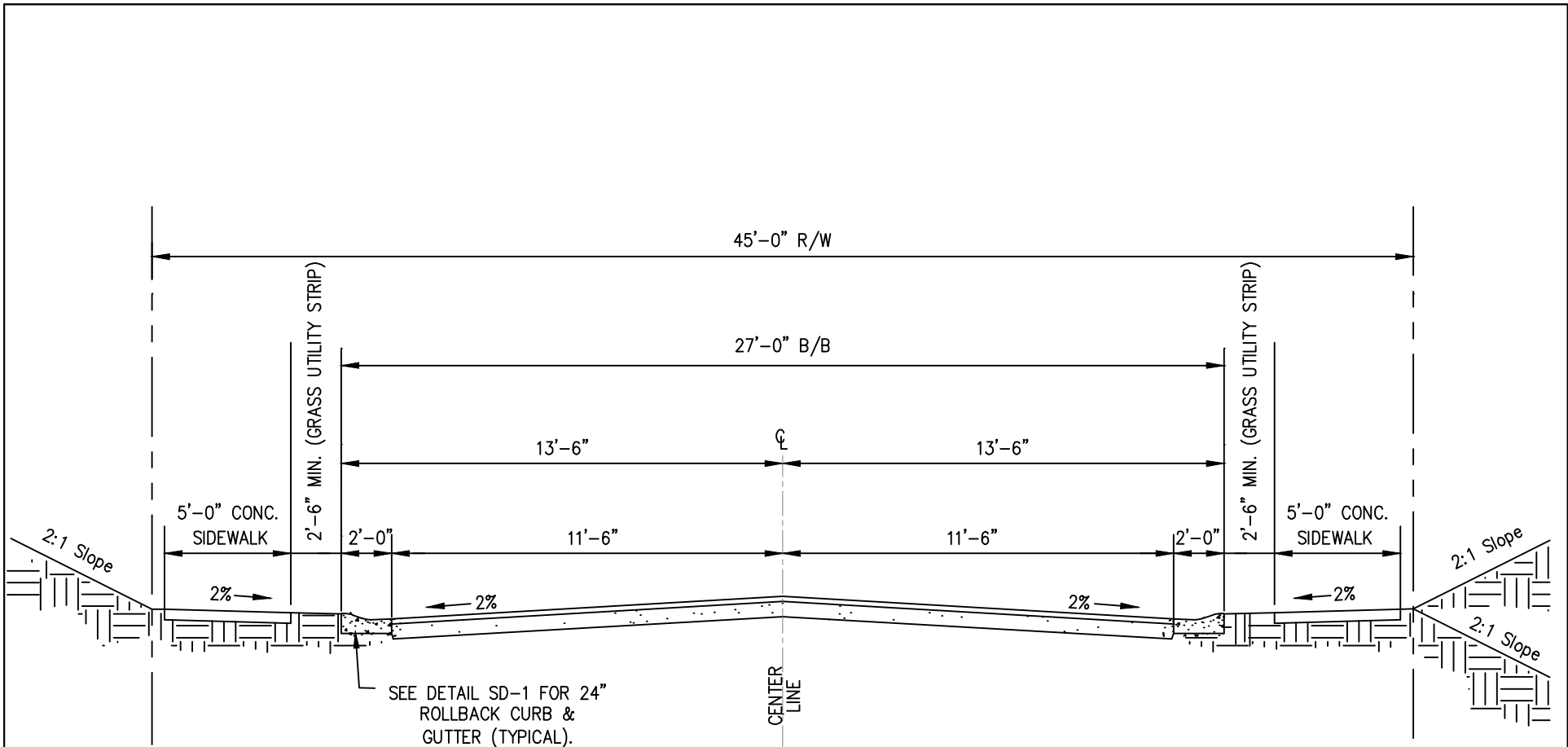

NOTES:

1. NORMAL CROWN OF 0.02' PER FOOT UNLESS OTHERWISE APPROVED BY THE CITY ENGINEER.
2. PAVEMENT DESIGN SHALL BE AS SHOWN ON DETAIL SD-16.2, TYPICAL #1 RESIDENTIAL STREETS.
3. ALL PERMANENT MARKINGS SHALL BE THERMOPLASTIC. DESIGN TO BE APPROVED BY CITY TRAFFIC ENGINEER.

Fayetteville
North Carolina

ENGINEERING DIVISION
 433 HAY ST. 28301
 (910) 433-1656
<http://www.fayettevillenc.gov>

**TYPICAL MINIMUM
 STANDARD 2 LANE STREET
 SECTION FOR RESIDENTIAL USE**

Rev. Date: 16JAN18
 Not to Scale

SD-14

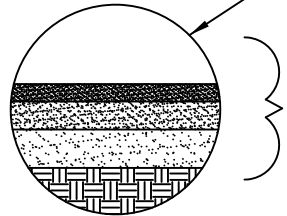
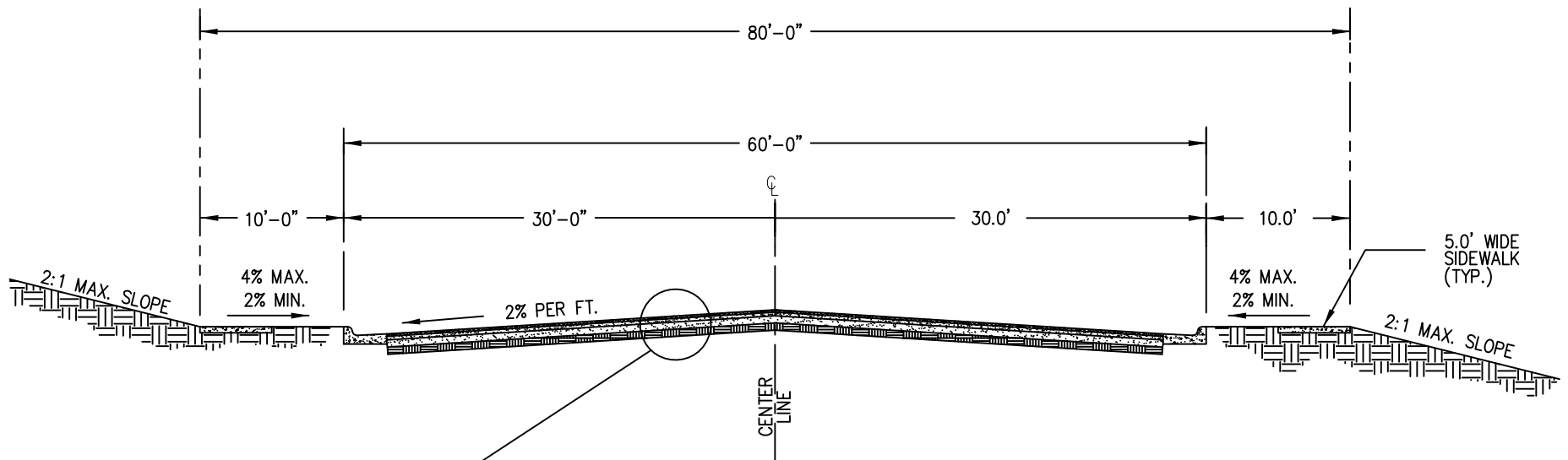

SEE DETAIL SD-16.2 TYPICAL CROSS SECTIONS FOR ALL CITY PAVEMENT.

Fayetteville
North Carolina

ENGINEERING DIVISION
433 HAY ST. 28301
(910) 433-1656
<http://www.fayettevillenc.gov>

**TYPICAL STREET SECTION FOR 60'
PVM'T (VERTICAL CURB)**

Rev. Date: 01MAY18
Not to Scale

SD-15

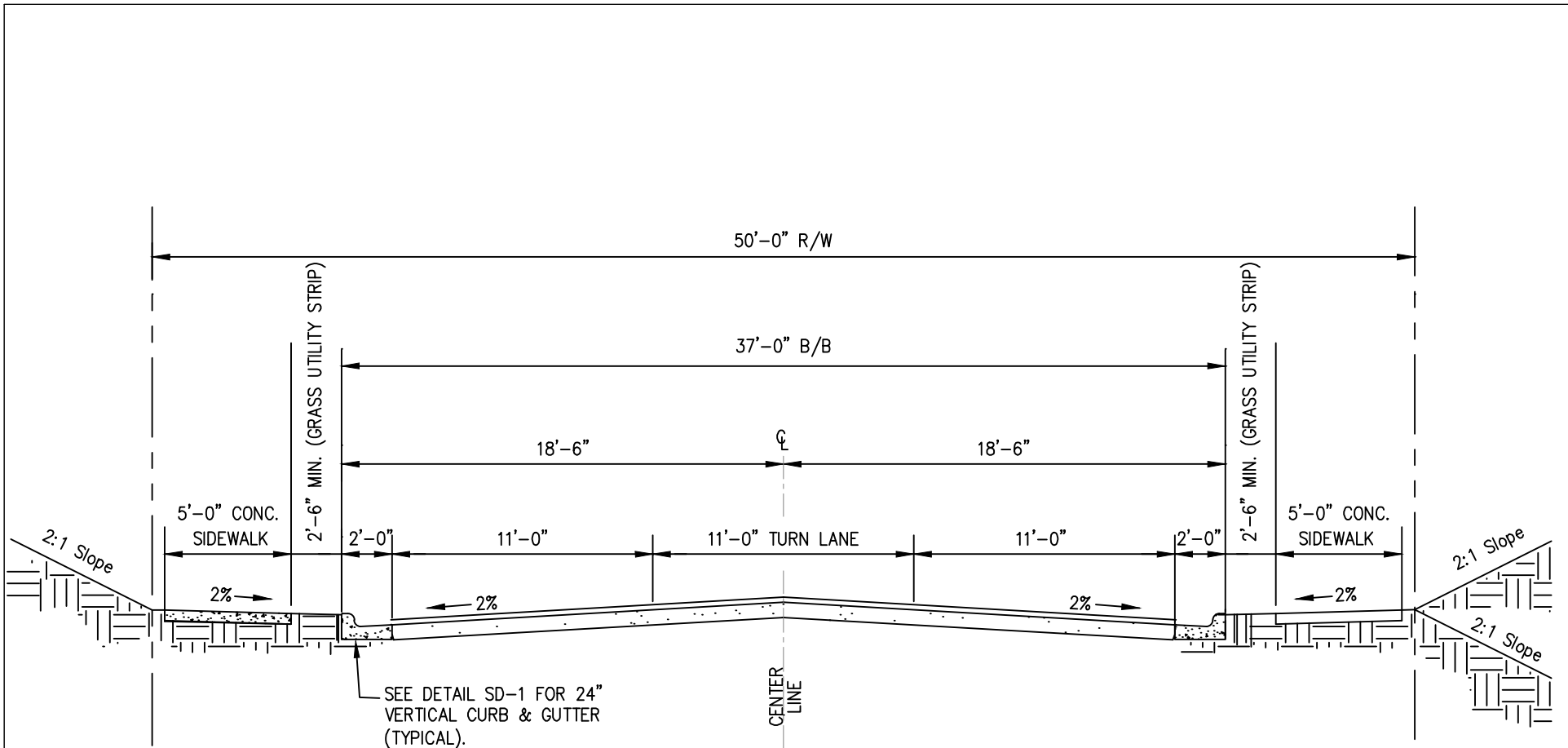

NOTES:

1. NORMAL CROWN OF 0.02' PER FOOT UNLESS OTHERWISE APPROVED BY THE CITY ENGINEER.
2. PAVEMENT DESIGN SHALL BE AS SHOWN ON DETAIL SD-16.2, TYPICAL # 2 OR 3 DEPENDING ON USE.
3. ALL PERMANENT MARKINGS SHALL BE THERMOPLASTIC. DESIGN TO BE APPROVED BY CITY TRAFFIC ENGINEER.

Fayetteville
North Carolina

ENGINEERING DIVISION
 433 HAY ST. 28301
 (910) 433-1656
<http://www.fayettevillenc.gov>

**TYPICAL MINIMUM SECTION FOR
 3 LANE STREETS**

Rev. Date: 16JAN18
 Not to Scale

SD-16

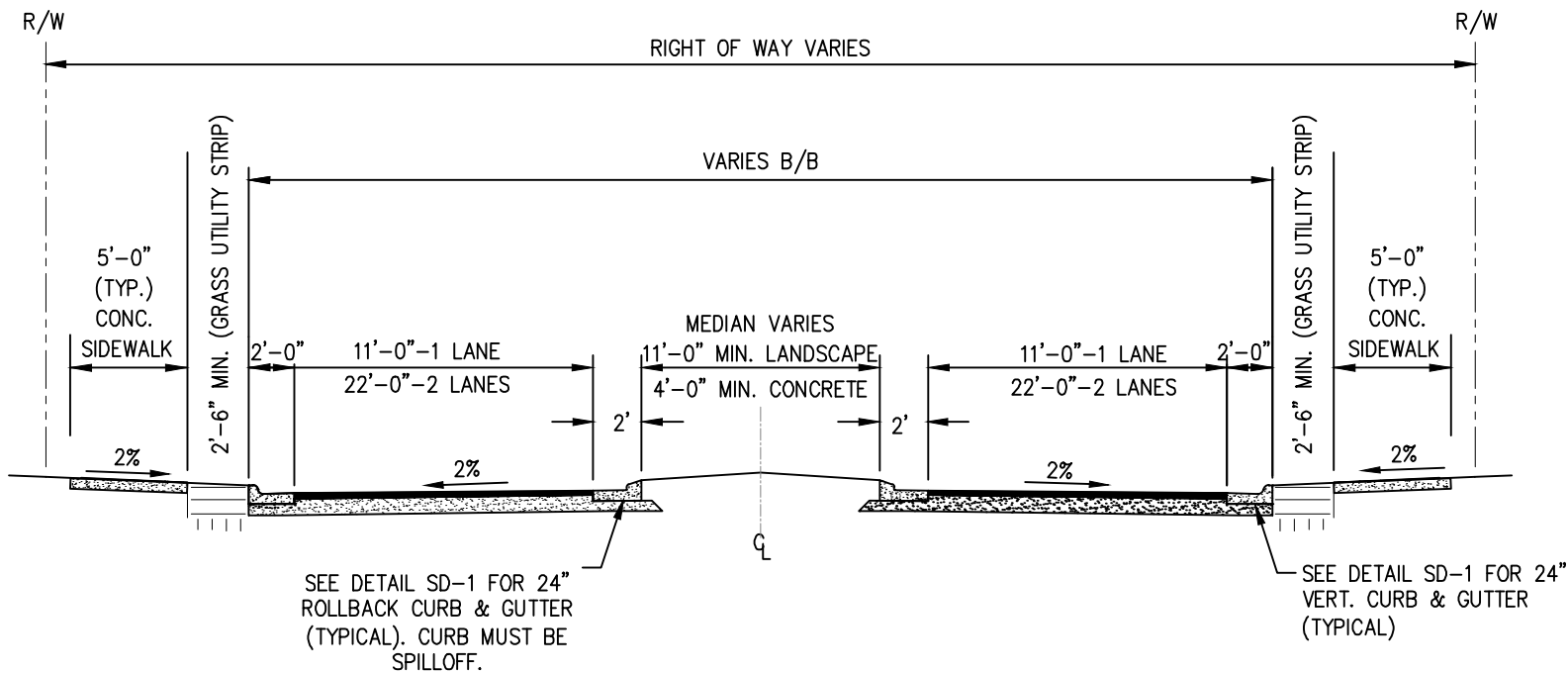

NOTES:

1. NORMAL CROWN OF 0.02' PER FOOT UNLESS OTHERWISE APPROVED BY THE CITY ENGINEER
2. PAVEMENT DESIGN SHALL BE AS SHOWN ON DETAIL SD-16.2
3. ALL PERMANENT MARKINGS SHALL BE THERMOPLASTIC. DESIGN TO BE APPROVED BY CITY TRAFFIC ENGINEER

Fayetteville
North Carolina

ENGINEERING DIVISION
 433 HAY ST. 28301
 (910) 433-1656
<http://www.fayettevillenc.gov>

**TYPICAL MINIMUM
 STANDARD STREET SECTIONS
 FOR 2 LANE AND 4 LANE
 DIVIDED STREETS WITH MEDIAN**

Rev. Date: 16JAN18
 Not to Scale

SD-16.1

TYPICAL RESIDENTIAL CROSS SECTION

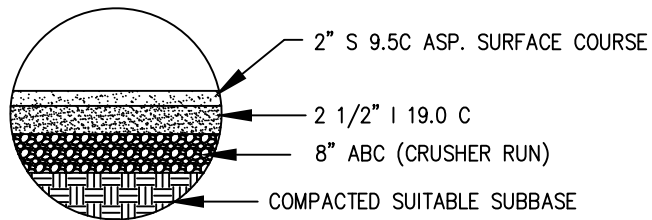
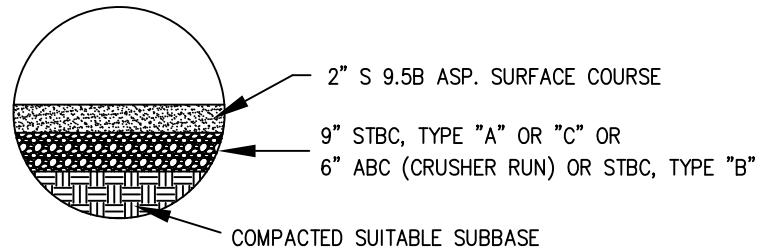

TYPICAL LIGHT COMMERCIAL CROSS SECTION

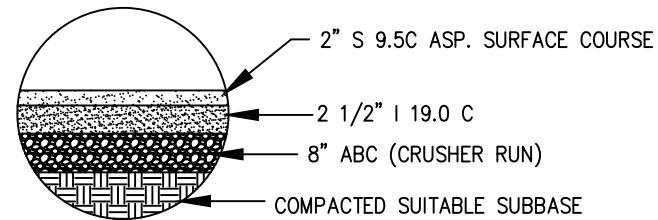

TYPICAL HEAVY COMMERCIAL CROSS SECTION



ENGINEERING DIVISION
 433 HAY ST. 28301
 (910) 433-1656
<http://www.fayettevillenc.gov>

TYPICAL CROSS SECTIONS FOR
 ALL CITY PAVEMENT

Rev. Date: 01MAY18
 Not to Scale

SD-16.2